

Assembly Equipment

Table of Contents

Index to Crimp Packages	N-2 thru N-3
Crimping Machines - Portable	
Coll-O-Crimp Portable T-464 & T-466	N-4
Coll-O-Crimp Portable T-465	N-5 thru N-6
Coll-O-Crimp T-465 Crimping Procedures	N-7
Air Conditioning Portable Crimper, T-477	N-8
T-477 Crimping Procedures	N-9 thru N-12
Coll-O-Crimp Portable T-480	N-13 thru N-15
ET1000 Portable Crimp Machine	N-16
ET1000 Crimp Procedures	N-17
Crimping Machines - Stationary	
Coll-O-Crimp Shop Press Tooling, T-400-17	N-18
Coll-O-Crimp I, T-400, T-407	N-19 thru N-20
Coll-O-Crimp SUPER I, T-420	N-21
Coll-O-Crimp ET4001	N-22
T-440, ET4000 & ET4001 Repair Items	N-23
Crimping Machines - Variable	
Coll-O-Crimp ET4020	N-24
Coll-O-Crimp ET4040	N-25

Tooling and Accessories

Coll-O-Crimp Collet Kits	N-26 thru N-29
WeatherGRIP Tooling	N-30 thru N-31
Coll-O-Crimp Spacer Rings	N-32
Coll-O-Crimp Air & Hydraulic Pumps	N-33 thru N-35
Competitor Conversion Kits	N-36
Tube Flaring Tools	N-37
Hose Cutting Equipment	N-38 thru N-40
Presetting Tools	N-41
Hose Bore Cleaning Brushes	N-42
Skiving Tools & Wrenches	N-43
Power Steering Assembly	N-44 thru N-46
Cable Controls	N-47 thru N-48
Assortments	N-49 thru N-67
Equipment	
Cabinets, Tool Boxes, and Plastic Bags	N-68 thru N-70
Label Sets & Mylar Hose Labels	N-71
Field Attachable Assembly	N-72 thru 73



Index

Weatherhead Crimp Machine and Tooling Packages

Portable Crimpers

Base Machine #	Part Number	Package Contents *	Hose fitting sizes crimped**				Catalog Page
			U-Series	Z-Series	430U	4SP/6SP	
T-465	T-465-HPU	T-465 vice mounted press, hand pump	-4 to -8	–	–	–	N-5
T-460	T-460	T-460 press, hand pump	–	–	–	–	N-4
T-460	T-462	T-462 press, air/hydraulic pump	–	–	–	–	N-4
T-460	T-464	T-460, collets and spacers	-4 to -8	–	–	–	N-4
T-460	T-466	T-462, collets and spacers	-4 to -8	–	–	–	N-4
T-460	ET460TP-0001	Z tooling for -4 to -8	–	-4 to -8	–	–	N-30
T-480	T-480-AH	T-480 press, hand lever air/hydraulic pump	–	–	–	–	N-13
T-480	T-480-HP	T-480 press, hand pump	–	–	–	–	N-13
T-480	T-480-EP	T-480 press, 110v pump	–	–	–	–	N-14
T-480	T-480-TA	T-480 press, foot treadle air/hydraulic pump	–	–	–	–	N-14
T-480	T-480-80	U and 430U tooling for T-480 press	-4 to -16	–	-8 to -20	–	N-28
T-480	ET480-001	T-480-HP press, pump, Z tooling	–	-4 to -16	–	–	N-14
T-480	ET480-002	T-480-AH press, pump, Z tooling	–	-4 to -16	–	–	N-14
T-480	ET480-003	T-480-TA press, pump, Z tooling	–	-4 to -16	–	–	N-14
T-480	ET480-004	T-480-EP press, pump, Z tooling	–	-4 to -16	–	–	N-14
T-480	ET480TP-0001	Z tooling for -4 to -16	–	-4 to -16	–	–	N-30
ET1000	ET1000-001	ET1000 press only	–	–	–	–	N-16
ET1000	ET1000-002	ET1000 press, hand pump	–	–	–	–	N-16
ET1000	ET1000-003	ET1000 press, air/hydraulic pump	–	–	–	–	N-16
ET1000	ET1000-004	ET1000 press, 110v pump	–	–	–	–	N-16
ET1000	ET1000-005	ET1000 press, 12v DC pump	–	–	–	–	N-16
ET1000	ET1000-016	ET1000-002, hand pump, Z tooling	–	-4 to -16	–	–	N-16
ET1000	ET1000-017	ET1000-003, air/hydraulic, Z tooling	–	-4 to -16	–	–	N-16
ET1000	ET1000-018	ET1000-004, 110v pump, Z tooling	–	-4 to -16	–	–	N-16
ET1000	ET1000TP-0001	Z tooling for -4 to -16	–	-4 to -16	–	–	N-30

Stationary Crimpers: Coll-O-Crimp 1 Series (thru 1-1/4" 2-wire)

Base Machine #	Part Number	Package Contents *	Hose fitting sizes crimped**				Catalog Page
			U-Series	Z-Series	430U	4SP/6SP	
T-400	T-400	T-400-1 press, tooling, (no pump)	-4 to -16	–	–	–	N-19
T-400	T-400-1	T-400-1 press only	–	–	–	–	N-19
T-400	T-401	T-400, 220v 1 phase pump, U tooling	-4 to -16	–	–	–	N-19
T-400	T-401-110	T-400, 110v 1 phase pump, U tooling	-4 to -16	–	–	–	N-19
T-400	T-402	T-400, air/hydraulic pump, U tooling	-4 to -16	–	–	–	N-19
T-400	T-403	T-400, hand pump, U tooling	-4 to -16	–	–	–	N-19
T-400	T-407-1	T-407-1 press only	–	–	–	–	N-20
T-400	T-407	T-407-1, high-volume pump and foot switch	–	–	–	–	N-20
T-400	T-414	T-400, 12v DC pump	-4 to -16	–	–	–	N-19
T-400	ET400-001	T-400-1, 220v 1 phase pump, Z tooling	–	-4 to -16	–	–	N-19
T-400	ET400-002	T-400-1, 110v 1 phase pump, Z tooling	–	-4 to -16	–	–	N-19
T-400	ET400-003	T-400-1, air/hydraulic pump, Z tooling	–	-4 to -16	–	–	N-19
T-400	ET400TP-0001	Z tooling for -4 to -16	–	-4 to -16	–	–	N-30

* Hose assembly included if pump is included.

** Collets and spacers to crimp fitting size ranges noted are included in packages except -10 size collets/dies typically not included. Check catalog for details.

Index

Weatherhead Crimp Machine and Tooling Packages

Stationary Crimpers: Coll-O-Crimp Super 1 Series (thru 1-1/4" 6-wire)

Base Machine #	Part Number	Package Contents *	Hose fitting sizes crimped**				Catalog Page
			U-Series	Z-Series	430U	4SP/6SP	
T-420	T-420-1	T-420-1 press only	-	-	-	-	N-21
T-420	T-420-N	T-420-1, T-421U 220v pump, U & 430U tooling	-4 to -16	-	-8 to -20	-	N-21
T-420	T-420N-110	T-420-1, T-421U-110 110v pump, U & 430U tooling	-4 to -16	-	-8 to -20	-	N-21
T-420	ET420-002	T-420-1, T-421U 220v pump, Z tooling	-	-4 to -16	-	-	N-21
T-420	ET420-003	T-420-1, T-421U-110 110v pump, Z tooling	-	-4 to -16	-	-	N-21
T-420	ET420-004	T-420-1, T-421U 220v pump, Z & 430U tooling	-	-4 to -16	-8 to -20	-	N-21
T-420	ET420-005	T-420-1, T-421U-110 110v pump, Z & 430U tooling	-	-4 to -16	-8 to -20	-	N-21
T-420	ET420TP-0001	Z tooling for -4 to -16	-	-4 to -16	-	-	N-30

Stationary Crimpers: Coll-O-Crimp ET4001 (thru 2")

Base Machine #	Part Number	Package Contents *	Hose fitting sizes crimped**				Catalog Page
			U-Series	Z-Series	430U	4SP/6SP	
ET4001	ET4001-002	ET4001 press only (no pump or valve)	-	-	-	-	N-22
ET4001	ET4001-004	ET4001 press, ET4001P-001 220v 1 phase pump	-	-	-	-	N-22
ET4001	ET4001-006	ET4001-004 plus 430U collets	-	-	-8 to -32	-	N-22
ET4001	ET4001-010	ET4001-004 plus 4SP/6SP collets	-	-	-	-12 to -32	N-22
ET4001	ET440TP-0001	Z tooling for -4 to -16	-	-4 to -16	-	-	N-30
ET4001	FF91047	Coll-O-Cart	-	-	-	-	N-23

Variable Crimpers: ET4020 (thru 1 1/4") and ET4040 (thru 2")

Base Machine #	Part Number	Package Contents *	Hose fitting sizes crimped**				Catalog Page
			U-Series	Z-Series	430U	4SP/6SP	
ET4020	ET4020-115	ET4020 press, 115v pump	-	-	-	-	N-24
ET4020	ET4020-230	ET4020 press, 230v pump	-	-	-	-	N-24
ET4020	ET4020TP-0003	Tooling- full set of die cages	-	-4 to -20	-6 to -20	-	N-24
ET4020	ET4020-006	ET4020-115 plus ET4020TP-003 tooling	-	-4 to -20	-6 to -20	-	N-24
ET4040	ET4040-115	ET4040 press, 115v pump	-	-	-	-	N-25
ET4040	ET4040-230	ET4040 press, 230v pump	-	-	-	-	N-25
ET4040	ET4040TP-0004	Tooling- full set of die cages for Z & 430U	-	-4 to -32	-6 to -32	-	N-25
ET4040	ET4040TP-0005	Tooling- full set of die cages for 4SP/6SP	-	-	-	-12 to -32	N-25
ET4040	ET4040TP-0006	Tooling- full set of die cages for Z & 430U & 4SP/6SP	-	-4 to -32	-6 to -32	-12 to -32	N-25
ET4040	ET4040-007	ET4040-115, ET4040TP-0004, master cage & handle	-	-4 to -32	-6 to -32	-	N-25
ET4040	ET4040-008	ET4040-115, ET4040TP-0005, master cage & handle	-	-	-	-12 to -32	N-25
ET4040	ET4040-009	ET4040-115, ET4040TP-0006, master cage & handle	-	-4 to -32	-6 to -32	-12 to -32	N-25

* Hose assembly included if pump is included.

** Collets and spacers to crimp fitting size ranges noted are included in packages except -10 size collets/dies typically not included. Check catalog for details.

Crimping Machines - Portable

Coll-O-Crimp Portable T-464



Refer to pages A-2 and A-3 and machine operator's manuals for safety information.

T-464 • Portable Coll-O-Crimp w/Hand Pump



For T-460 Tool Box see page N-6.

Reference pages N-2 and N-3 for COC machine and tooling packages, and pages N-26 to N-30 for collet kits and spacer ring details.

Refer to pages A-2 and A-3 and machine operator's manuals for safety information.

The T-460 is a completely portable hose assembly system. Lightweight, hand pump-powered, and complete with a self-supporting base, this crimping press features layback positioning up to a 45° angle.

Capacity: 3/16" I.D. 1-fiber braid through 1-3/8" I.D. 1-wire hose and 1-1/4" 2-wire hose.

Mounting:
Free-standing base

Size: 15" high, 14" wide, 11-1/4" deep

Weight: 62 lbs

T-464 • Portable Coll-O-Crimp w/Hand Pump Package

Includes one each of the following:

Catalog Number	Description
T-460	Portable Coll-O-Crimp Press, Hand Pump & Hose Assembly Kit, W-EQCR-TM008-E Instructions
T-400-2C	"U" Series Collet – 1/4"
T-400-3C	"U" Series Collet – 3/8"
T-400-4C	"U" Series Collet – 1/2"
T-400-10	Black Spacer Ring
T-400-62	Yellow Spacer Ring

Repair and Replacement Items

Catalog Number	Description	Catalog Number	Description
W-EQCR-TM008-E	Instructions	T-460-P	Pusher
T-460-SPR	Slide Pull Rod	T-460-SF	Slide Flange
T-460-16	Hose Assembly	T-460-SP	Slide Plate
T-460-2	Hand Pump	T-460-SPK	Slide Pull Knob
W-EQCR-TE009-E	Shroud Decal	E-EQCR-ME002-E	Instructional Video

For replacement pump see page N-33.

T-466 • Portable Coll-O-Crimp w/Air Hydraulic Pump



For T-462 Tool Box see page N-6.

Reference pages N-2 and N-3 for COC machine and tooling packages, and pages N-26 to N-30 for collet kits and spacer ring details.

Refer to pages A-2 and A-3 and machine operator's manuals for safety information.

This portable Coll-O-Crimp features an air/hydraulic pump making it the ideal system if you have the availability of compressed air in your shop or in the field via a portable compressor.

Capacity: 3/16" I.D. 1-fiber braid through 1-3/8" I.D. 1-wire hose and 1-1/4" 2-wire hose.

Mounting:
Free standing base

Size: 15" high, 14" wide, 11-1/4" deep

Weight: 62 lbs

T-466 • Portable Coll-O-Crimp w/Air Hydraulic Pump Package

Includes one each of the following:

Catalog Number	Description
T-462	Portable Coll-O-Crimp Press, Air/Hydraulic Pump & Hose Assembly Kit, W-EQCR-TM008-E Instructions
T-400-2C	"U" Series Collet – 1/4"
T-400-3C	"U" Series Collet – 3/8"
T-400-4C	"U" Series Collet – 1/2"
T-400-10	Black Spacer Ring
T-400-62	Yellow Spacer Ring

Repair and Replacement Items

Catalog Number	Description	Catalog Number	Description
W-EQCR-TM008-E	Instructions	T-460-SPK	Slide Pull Knob
T-460-P	Pusher	T-460-SPR	Slide Pull Rod
T-460-SF	Slide Flange	T-462-16	Hose Assembly
T-460-SP	Slide Plate	T-462-V	Regulator only
W-EQCR-TE010-E	Shroud Decal	T-462-2	Air/Hydraulic Pump
140-06675	Air Regulator Kit	E-EQCR-ME002-E	Instructional Video

For replacement pump see page N-33.

Crimping Machines - Portable

Coll-O-Crimp Portable T-465

 Refer to pages A-2 and A-3 and machine operator's manuals for safety information.

Portable Coll-O-Crimp



The Portable Coll-O-Crimp is a completely PORTABLE hose assembly system. NO ELECTRICAL POWER SOURCE IS NEEDED. Hand pump powered, lightweight, vise or stand mounted, this crimper is ideal for your portable crimping needs.

Capacity

3/16" I.D. 1-fiber braid through 1-3/8" I.D.
1-wire hose and 1-1/4" 2-wire hose

Mounting

Vise/Stand

Size

12-1/2" high, 8-1/2" wide, 5-1/2" deep

Weight

31 lbs

The vise bracket, die ring, pusher, decal and instruction kit are components of the T-465 Portable Coll-O-Crimp Press.

Pump Required

(sold separately): T-460-2

T-465

Portable Coll-O-Crimp Press ONLY

CAUTION

Use T-460-2 10,000 PSI hand pump only.

CAUTION

The Coll-O-Crimp power source has the pressure relief valve set at 10,000 PSI. Damage to the press will result if higher pressures are used and warranty will be voided.

Reference pages N-2 and N-3 for COC machine and tooling packages, and pages N-26 to N-30 for collet kits and spacer ring details.

Refer to pages A-2 and A-3 and machine operator's manuals for safety information.

T-465-HP • Portable Coll-O-Crimp Package

Includes one each of the following:

Catalog Number	Description
T-465	Portable Coll-O-Crimp Press
T-460-2	Hand Pump (10,000 PSI)
T-450-3	Quick Disconnect Hose Assembly

For replacement pump see pages N-33-35.

T-465 HPU • Portable Coll-O-Crimp Package

Includes one each of the following:

Catalog Number	Description
T-465-HP	Portable Coll-O-Crimp Package
T-400-2C	"U" Series Collet – 1/4"
T-400-3C	"U" Series Collet – 3/8"
T-400-4C	"U" Series Collet – 1/2"
T-400-10	Black Spacer Ring
T-400-62	Yellow Spacer Ring

Crimping Machines - Portable

Coll-O-Crimp Portable T-465

 Refer to pages A-2 and A-3 and machine operator's manuals for safety information.

T-450-C • Portable Coll-O-Crimp Stand

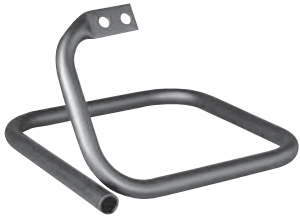

The T-450-C Stand is designed specifically for your Portable Coll-O-Crimp T-465 Press. This stand allows you to use your press on a work bench or other flat surface without the need of a vise. Simply bolt the press onto the stand with the supplied bolts, and you're ready to make Coll-O-Crimp Hose Assemblies.

Refer below for repair and replacement items.

T-465-TB • Portable Coll-O-Crimp Tool Boxes



The T-465-TB tool boxes feature convenient press, pump and collet storage while offering easy mobility of your hose assembly equipment. Supplied as a set, the T-465-TB tool boxes are an excellent addition to the portable Coll-O-Crimp System.

Refer below for repair and replacement items.

Includes one each:

Catalog Number	Description
T-460-10B	Small Tool Box Stores the T-465 and spacer rings. 15" x 9" x 8".
T-460-10BB	Large Tool Box Stores the T-460-2 and collets. 25" x 10" x 8".

T-450/T-465 Portable Coll-O-Crimp Repair and Replacement Items

Catalog Number	Description
T-450-D1	Spacer Ring Selector Decal for Nylon Hose (H009, H209, H243, H435, and H436)
T-450-P	Pusher
T-450-Q	Quick Disconnect Coupling
T-450K	Pusher and Retainer Plate Repair Kit. Includes: T-450B Pusher bolt (1) T-450R Retainer plate (1) T-450S Retainer plate screw (2)
W-EQCR-TE011-E	Shroud Decal

Crimping Machines - Portable

T-465-1 Crimping Procedure

WARNING

You must hold the hose assembly in place from below throughout the crimping operation. Do not place fingers or hands at the crimping point during operation. Failure to follow this procedure could result in serious bodily injury.



- Clamp the crimper into a vise or mount to a work bench using the mounting bracket.

Note:

Lubricate the tapered cone seat with T-400-G grease or equivalent before any crimping is completed. Continued periodic lubrication is necessary.



- Select proper Coll-O-Crimp hose and end fitting. Insert hose into end fitting, hose is bottomed in end fitting.
- Remove pusher and insert proper size collet halves. Refer to crimp bulletin W-HOOV-TM001-E2.

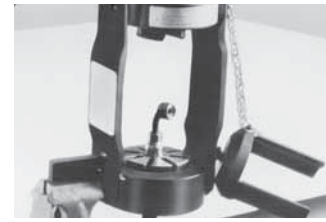

- Insert hose assembly from below between the collet halves. Align the hose end with the top of the collet in the proper location.



- Refer to crimp bulletin W-HOOV-TM001-E2 for proper spacer ring. Place appropriate spacer ring, with the proper orientation, on top of collet. Hold uncrimped hose assembly in place throughout crimping operation.



1. Replace pusher by hanging it from ramplate with bolt on top. Slide it back for centering. Close valve on hand pump and start pumping to crimp.



- When spacer ring contacts die ring, the crimp is complete. Open valve on hand pump. Allow the ram and pusher to retract.
- Remove pusher and spacer ring. Remove crimped assembly from below through the collet halves. Visually inspect the crimped end.
- To ensure a proper crimp has been completed, measure the nominal crimp diameter and verify the proper crimp length and crimp location. Refer to crimp bulletin W-HOOV-TM001-E2.

Crimping Machines - Portable

Air Conditioning Portable T-477

 Refer to pages A-2 and A-3 and machine operator's manuals for safety information.

T-477-1 • Portable Air Conditioning Press



This hand operated, lightweight and easy-to-use air conditioning press is engineered and designed specifically for use with Weatherhead 757 "E" series hose end fittings. Perfect for bench mounting this portable press is made of heavy-duty construction for use with an air-impact wrench. Uses color-coded urethane-encased

dies and a removable die holder to accommodate complicated shapes. Uses four standard die sizes (#6, #8, #10, and #12) that produce an OE-style triple-bubble crimp. No electrical requirements necessary.

Capacity: Crimps 2-braid dimension nylon barrier or reduced-diameter hose.

Mounting:

Bench or mount in vise

Weight: 6 lbs.

Reference pages N-2 and N-3 for COC machine and tooling packages, and pages N-26 to N-30 for collet kits and spacer ring details.

Refer to pages A-2 and A-3 and machine operator's manuals for safety information.

T-477 • Portable Air Conditioning Package



Package includes:

Part Number	Description
T-477-1	Portable A/C Press
T-477-105C	#6 Die Set - Red
T-477-106C	#8 Die Set - Black
T-477-107C	#10 Die Set - Almond
T-477-108C	#12 Die Set - Green

Includes Bench Mount Flange, Die Set Lubricant and Steel Pipe Nipple Extension. Also includes a Custom Carrying Case with Instructions.

Crimping Machines - Portable

T-477-1 Crimping Procedure

 Refer to pages A-2 and A-3 and machine operator's manuals for safety information.

T-477-1 Crimp Die Sets

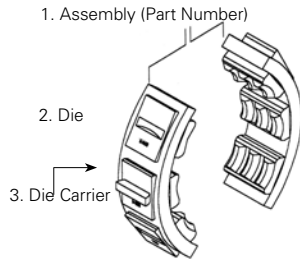

T-477-1 Die Set Information

Item	Description	Quantity	6	8	10	12
1	Assembly Part Number	1 set	T-477-105C	T-477-106C	T-477-107C	T-477-108C
2	Die Marking	-	6R556	8R655	10R742	12R897
3	Die Carrier Color	-	Red	Black	Almond	Green

For use with H757 Hose and 757 "E" Series Hose Ends.

T-477-1 Crimper Parts List

When ordering T-477-1 spare parts, contact: www.atcoproductsinc.com or Email: info@atcomail.com or call: 1-972-842-8178.

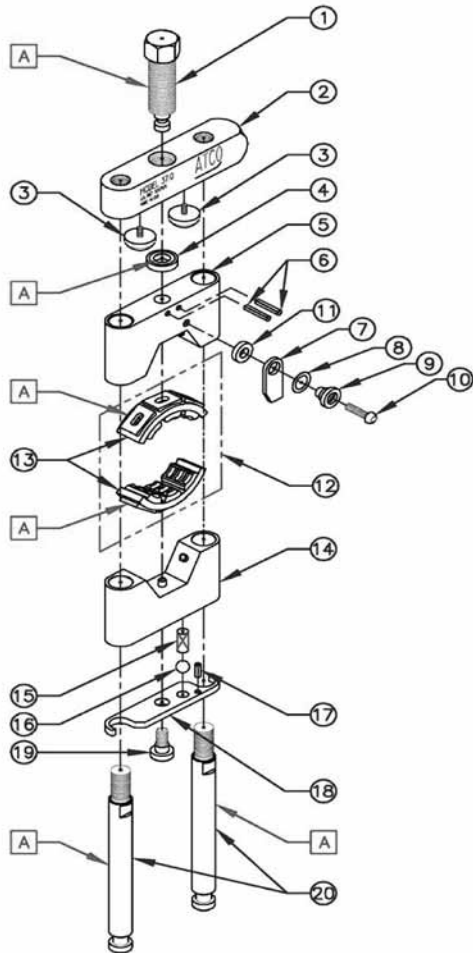

Parts List

Item	Description	Qty	Part No.
1	Actuator Screw	1	75013
2	Actuator Bar	1	75177
3	Rubber Bumper	2	75012
4	Thrust Bushing	1	75149
5	Movable Die Holder	1	75175
6	3/16 x 1 Roll Pin	2	75010
7	Locator Flag*	1	75086-Y
8	Curved Disc Spring	1	75088
9	Locator Bushing	1	75087-Y
10	1/4-20 x 1 Button Head Screw*	1	75113
11	Spacer Bushing	7	75176
12	See Crimp Die List	1	See Item 1 (top)‡
13	Crimp Die Carrier	1	See Item 1 (top)‡
14	Removable Die Holder**	1	75174
15	Spring-Compression**	1	75076
16	7/16 Diameter Ball**	1	75077
17	3/16 x 1/2 Roll Pin**	1	75009
18	Latch Plate	1	75074
19	Lock Screw**	1	75008
20	Strain Rod	2	75020

‡ References Item 1 in Die Set Chart at the top of the page.

Items Not Shown

Item	Description	Qty	Part No.
A	Grease	1	75015
B	3/8 x 4 Pipe Nipple	1	75016
C	3/8 Flooring Flange	1	90607
D	Carrying Case	1	75017

* Included in item 24 (Not assembled) / ** Included in item 25 (Assembled).

For use with H757 Hose and 757 "E" Series Hose Ends

Item	Description	Qty	6	8	10	12
-	Die Marking	-	6R556	8R655	10R742	12R897
26	Crimp Die No.	1 set	T-475-105C	T-475-106C	T-475-107C	T-475-108C
-	Color	-	Red	Black	Almond	Green
16	Die Carrier	2	75140	71688	75136	71690
15	Die Segment	6	71741	75119	71743	71744

Crimping Machines - Portable

T-477-1 Crimping Procedure

Model T-477 Portable Air Conditioning Hose Crimping Kit

Description of terms

The crimper can be operated with a 1/2" drive air impact wrench, ratchet or breaker bar. It takes approximately 100 foot pounds of torque to fully close the jaws and achieve a satisfactory crimp. The crimper can be bench mounted using the flange and pipe nipple provided or it can be mounted in a bench vise to stabilize the unit. If the unit is used in a service vehicle with a mounted vice, it will be necessary to use a 12" minimum extension to the pipe nipple to counteract the torque while closing the dies. This extension is not provided in the kit.

Bench mount: Bolt the flange to a bench top. Screw the pipe nipple and crimper to the flange plate.

Impact wrench (1/2" Drive @ 100 PSIG Max.): Use a 1" impact socket to drive the movable die holder.

⚠ CAUTION

Do not exceed 100 PSIG air pressure on the impact wrench as damage to the wrench and the crimper may result.

⚠ CAUTION

Do not continue impacting after the dies are closed. This can cause damage to the crimper.

⚠ CAUTION

Care should be taken when reversing the impact so that the die holder does not slam into the crimper body (actuator bar, Item 2). Bumpers are provided to minimize damage.

Ratchet or breaker bar:

Use a 1" socket to drive the movable die holder. It will take approximately 100 foot pounds of torque to achieve a full crimp.

Removable die holder:

The bottom of the crimper can be removed to accommodate special shapes or under-hood crimping. Push the latch plate (Item 21) open while holding the removable die holder. Pull the holder off the strain rods.

Die change: With the removable die holder removed, loosen two of the button head screws (Item 12) on one side of the die holder. The die will drop out of the holder. Apply grease (Item B) to the slide surfaces. Squeeze the outer segments of the die set together and insert the die into the holder making sure that the Woodruff Key (Item 14) in the center segment snaps fully into the groove in the holder (Refer to Fig. 1).

While holding the die securely in the slot, retighten the two button head screws. Check to make sure that the two outer segments on each half are free to move. If they do not move freely, remove and inspect for damaged guide block pad or dirt.

⚠ CAUTION

Retention of the Woodruff Key in the slot while tightening the screws is most important. Failure to do so will result in an irregular crimp and damage to the guide blocks and Woodruff Key (Refer to Fig. 2).

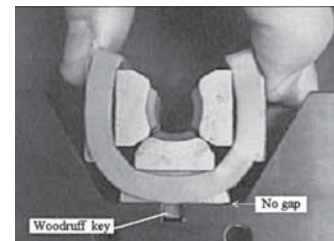
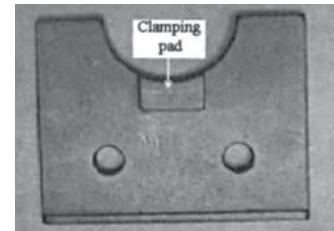

Figure 1

Die carrier properly inserted in holder.



Undamaged Pad

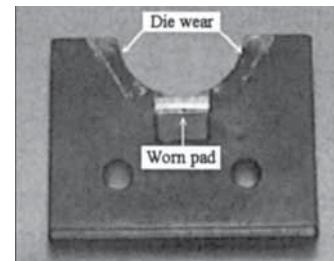

Figure 2

Damaged Pad

Crimping Machines - Portable

T-477-1 Crimping Procedure

! Refer to pages A-2 and A-3 and machine operator's manuals for safety information.

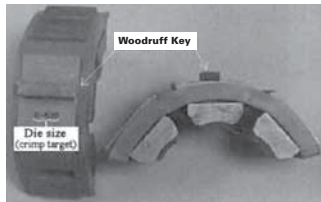
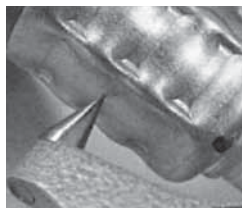

Figure 3

Dies with Woodruff Keys in place



Position of tip of micrometer

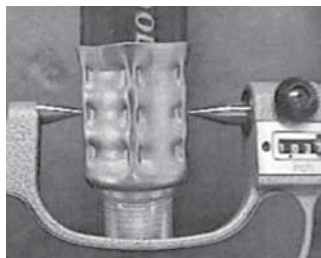

Figure 4

Measuring the crimp with a micrometer

! **CAUTION**

It is not necessary to over-tighten the screws. Always use the short hex key wrench provided in order to avoid damage.

Die Carrier

The die carriers will become worn and produce unacceptable crimps with time. To replace the color-coded die carriers, simply push the die segment out of the back of the carrier. Reverse the process to assemble die segments in the new carrier.

Woodruff Key

The Woodruff Key is bonded into the slot in the center die segment. It is used to align the dies in the die holders (Refer to Fig. 3).

! **CAUTION**

If the Woodruff Key is not in the center segment of each half of the die set, an irregular crimp will be formed increasing the probability of leakage.

! **CAUTION**

Never use dies without Woodruff Key engaged in the slot of the segment and holder.

To replace the Woodruff Key, use a screwdriver and hammer to remove the old key. Replace the key using a drop of adhesive such as Loctite® to hold the key securely.

Locator Flag

There is a locator flag on the crimper. It is spring loaded and movable to locate the end of the ferrule for proper crimp location. Swivel the flag to a position so that when the fitting is inserted into the crimper, the ferrule will stop in the proper location for crimping.

Crimp diameter measurement

The crimp diameter can be measured by using a set of point micrometers or calipers with a point accessory kit installed. Standard measuring instruments will not reach to the crimp impression because of the pinch of the crimp. When measuring the crimp diameter, take three measurements around the center crimp ring. Add the measurements, divide by three to get the average. The average should be the target crimp diameter (+.015/-0.005). Example: The #6 size is .556 target crimp diameter. The crimp should measure between .571 and .551 (Refer to Fig 4).

Hose Wall Thickness

The hose wall thicknesses for one-braid dimension hoses are listed below. It is important to check the hose wall thickness to make sure that the crimp will be leak free.

Hose size	Hose O.D.
#6 - 5/16 I.D.	9/16
#8 - 13/32 I.D.	11/16
#10 - 1/2 I.D.	3/4
#12 - 5/8 I.D.	15/16

Operation

- Mount the crimper as described previously unless it is necessary to mount it in the vice on the service vehicle.
- Select the proper size dies. Check all segments to make sure that all of the segments have the same numbers on the back. Each segment will be marked identifying the hose size and crimp diameter. Example: 5/16 ID hose with a .556 diameter crimp will be marked "556" (Refer to Fig. 3).
- Lubricate the slides of the crimper die holders (Items 5 and 17) and the screw thread (Item 1) with an appropriate grease (Item B).
- Refer to die change outlined above for proper assembly of the dies into the crimper.
- Position the locator flag (Item 8) so the ferrule of the fitting bumps it on the side when inserted into the crimper.

! **CAUTION**

Do not locate from the bead on the fitting. This will result in the wrong crimp location.

- Insert the hose into the fitting making sure that the hose appears in the small inspection hole on the side or end of the ferrule.

! **CAUTION**

If the hose does not appear in the inspection hole, a poor crimp may result.

Loctite® is a registered trademark of Loctite Corporation.

Crimping Machines - Portable

T-477-1 Crimping Procedure



Refer to pages A-2 and A-3 and machine operator's manuals for safety information.

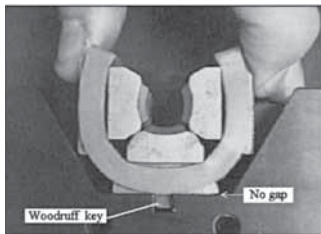

Figure 5

Crimp head completely closed.

*Refer to T-477-1 Crimper Parts List, page N-4.

- Place the assembly into the crimper and hold it against the locator flag. Only the ferrule should touch the flag. Operate the screw (Item 1) to close the dies to the full closed position. This will provide the proper compression to achieve a leak-free crimp. When the crimp dies are bottomed out, there will be a slight gap between the two die holders. This ensures that the dies are fully closed before the holders bottom out (Refer to Fig. 5).
- Reverse the screw (Item 1) to release the crimper from the hose assembly. Take care not to drive the die holder (Item 5) against the actuator bar (Item 2) as damage to the crimper may result. The bumpers (Item 3) are provided as a cushion to help prevent this from occurring.
- If the crimp is performed under-hood or the fitting is a complicated shape that requires disassembly of the crimper, open the latch plate (Item 18) and remove the die holder (Item 14).
- Inspect the first crimp to make sure that the correct dies were used, the crimp location is correct, the crimp is uniform and there is no internal deformation of the fitting.

Note:
See page N-9 for item references.

Note:
Some hose materials trap air in the hose layers during manufacture. When leak testing a newly pressurized hose using soap bubbles or water submersion, the air in the hose will bleed out at the fitting and hose interface indicating a false leaking condition. Leave the hose pressurized for one hour and retest. The residual air should completely bleed out and no leak will be visible.

Crimper Maintenance

- Clean and lubricate all moving parts. Use an appropriate grease (Item B) as needed when lubricating.
- Inspect the strain rods and latch plate for wear around the contact points.
- Make sure the actuator screw turns freely. Lubricate as noted above.
- Check for worn or torn die carriers. Replace when crimp appears to go out of round.
- Inspect Woodruff Keys. Replace if they are damaged or missing to ensure good crimps.

Troubleshooting

Problem	Cause	Action
1. Oblong or irregular crimp	<ul style="list-style-type: none"> Worn carriers One die segment in the set is the wrong size Woodruff Key missing Guide blocks installed backwards 	<ul style="list-style-type: none"> Replace carriers Check all segments for correct size on back of die Replace key Turn guide blocks around so raised pad clamps on die
2. Crimp diameter too large	<ul style="list-style-type: none"> Crimper not fully closed – refer to instructions Incorrect size dies 	<ul style="list-style-type: none"> Recrimp until dies fully close Replace with correct size
3. Crimp diameter too small	<ul style="list-style-type: none"> Incorrect size dies 	<ul style="list-style-type: none"> Replace with correct size
4. Crimp location too close to closed end of ferrule	<ul style="list-style-type: none"> Ferrule not inserted far enough into crimper 	<ul style="list-style-type: none"> Use locator flag to properly locate ferrule position
5. Crimp location too close to hose	<ul style="list-style-type: none"> Ferrule inserted too far into crimper (past locator flag) 	<ul style="list-style-type: none"> Use locator flag to properly locate ferrule position
6. Crimped fitting leaks when tested with soap bubbles	<ul style="list-style-type: none"> Air trapped in the hose during manufacture Insufficient crimp Hose wall thickness is undersize (see chart) Fitting is defective 	<ul style="list-style-type: none"> Recheck after system has been charged for one hour – air will bleed out of the hose Check crimp diameter Recrimp with .030 undersize die Replace fitting/recrimp
7. Crimped fitting leaks when tested with electronic leak detector	<ul style="list-style-type: none"> Insufficient crimp Hose wall thickness 	<ul style="list-style-type: none"> Check crimp diameter Recrimp with .030

Crimping Machines - Portable

Coll-O-Crimp Portable T-480



Refer to pages A-2 and A-3 and machine operator's manuals for safety information.

T-480-HP • Portable Coll-O-Crimp Press & Hand Pump Package



Reference pages N-2 and N-3 for COC machine and tooling packages, and pages N-26 to N-30 for collet kits and spacer ring details.

Refer to pages A-2 and A-3 and machine operator's manuals for safety information.

Make factory-type hose assemblies anywhere-anytime! Versatile and portable, this package offers the ease of use you are looking for in a Coll-O-Crimp hose assembly system. The T-480 Coll-O-Crimp Press packages are offered in four options. Listed below are press/power unit packages.

For cabinets see pages N-68-70 (not included).

Capacity

3/16" I.D. 1 fiber braid through 1-1/4" I.D. 6 spiral hose

Mounting

Free Standing Base

Size

22-1/2" high, 14" long, 10-1/2" wide

Total Weight

112 lbs.

T-480-2 Pump Specifications:

Dimensions

7-3/16" high, 21-1/64" long, 4-3/4" wide

Pressure

0-10,000 psi

Outlet Port Size

3/8" NPT

Hydraulic Oil

Enerpac

Reservoir Capacity

55 cu. in.

Includes **T-480-68** blue pusher extension ring to be used with **T-480** Portable Coll-O-Crimp and the **T-420** and **ET420** collets only.

For replacement pump see pages N-33-35.

T-480-AH • Portable Coll-O-Crimp Press & Air/Hydraulic Pump Package

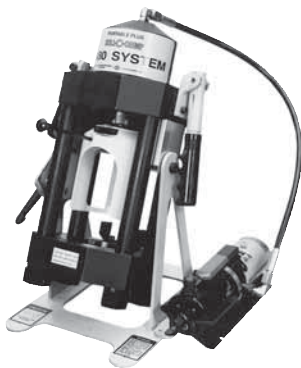

Reference pages N-2 and N-3 for COC machine and tooling packages, and pages N-26 to N-30 for collet kits and spacer ring details.

Refer to safety information regarding Coll-O-Crimp crimping procedures on pages N-4-17.

Capacity

3/16" I.D. 1 fiber braid through 1-1/4" I.D. 6 spiral hose

Mounting

Free Standing Base

Size

22-1/2" high, 14" long, 10-1/2" wide

Total Weight

124 lbs.

T-482-2 Pump Specifications:

Dimensions

5" high, 14-5/8" long, 5-5/8" wide

Pressure

0-10,000 psi

Outlet Port Size

3/8" NPT

Inlet Port

1/4" NPT

Pump Inlet Air Pressure

60-100 psi

Hydraulic Oil

Enerpac

Reservoir Capacity

36 cu. in.

Includes **T-480-68** blue pusher extension ring to be used with **T-480** Portable Coll-O-Crimp and the **T-420** and **ET420** collets only.

Note: It is recommended that a filter, regulator, lubricator, and air pressure gauge be installed upstream from the pump. Filter, regulator, and lubricator units are not included.

For replacement pump see pages N-33-35.

Crimping Machines - Portable

Coll-O-Crimp Portable T-480

 Refer to pages A-2 and A-3 and machine operator's manuals for safety information.

T-480-TA Portable Coll-O-Crimp Press and Turbo Air/Hydraulic Pump Package



Reference pages N-2 and N-3 for COC machine and tooling packages, and pages N-26 to N-30 for collet kits and spacer ring details.

Refer to pages A-2 and A-3 and machine operator's manuals for safety information.

Capacity
3/16" I.D. 1 fiber braid through 1-1/4" I.D. 6 spiral hose

Mounting
Free Standing Base

Size
22-1/2" high, 14" long, 10-1/2" wide

Total Weight
116 lbs.

T-480-3 Pump Specifications:

Dimensions
8-1/4" high, 12-3/8" long, 8" wide

Pressure
0-10,000 psi

Outlet Port Size
3/8" NPT

Inlet Port
1/4" NPT

Pump Inlet Air Pressure:
40-150 psi

Hydraulic Oil
Enerpac

Reservoir Capacity
150 cu. in.

Includes **T-480-68** blue pusher extension ring to be used with **T-480** Portable Coll-O-Crimp and the **T-420** and **ET420** collets only.

Note: It is recommended that a filter, regulator, lubricator, and air pressure gauge be installed upstream from the pump. Filter, regulator, and lubricator units are not included.

For replacement pump see pages N-33-35.

T-480-EP Portable Coll-O-Crimp Press and 110v Electric Pump Package



Reference pages N-2 and N-3 for COC machine and tooling packages, and pages N-26 to N-30 for collet kits and spacer ring details.

Refer to pages A-2 and A-3 and machine operator's manuals for safety information.

Capacity
3/16" I.D. 1 fiber braid through 1-1/4" I.D. 6 spiral hose

Mounting
Free Standing Base

Size
22-1/2" high, 14" long, 10-1/2" wide

Total Weight
134 lbs.

T-481-110 Pump Specifications:

Electrical Power Source
15amp, 110v grounded 1Ph 50/60HZ

Dimensions
14-1/4" high, 9-5/8" long, 9-5/8" wide

Pressure
0-10,000 psi

Outlet Port Size
3/8" NPT

Hydraulic Oil
Enerpac

Reservoir Capacity
115.5 cu. in.

Flow
.5 to 1.0 gpm

Motor Rating
1/2 hp universal, 9 amps at 10,000 psi

Includes **T-480-68** blue pusher extension ring to be used with **T-480** Portable Coll-O-Crimp and the **T-420** and **ET420** collets only.

For replacement pump see pages N-33-35.

Package #	ET480-001	ET480-002	ET480-003	ET480-004
Power source	Hand pump	Air/Hydraulic (Hand Switch)	Turbo Air/Hydraulic (Foot Pedal)	110V
Contents				
Press, Pump and Hose Assembly	T-480-HP	T-480-AH	T-480-TA	T-480-EP
Adapter Ring	T-420-25	T-420-25	T-420-25	T-420-25
Z-series tooling for -4 thru -16 (no -10) one wire and two wire	ET480TP-0001	ET480TP-0001	ET480TP-0001	ET480TP-0001

See pages N-26-32 for a breakdown of collets and spacer rings included in these packages.

Crimping Machines - Portable

Coll-O-Crimp Portable T-480

 Refer to pages A-2 and A-3 and machine operator's manuals for safety information.

T-480 • Portable Coll-O-Crimp Repair and Replacement Items

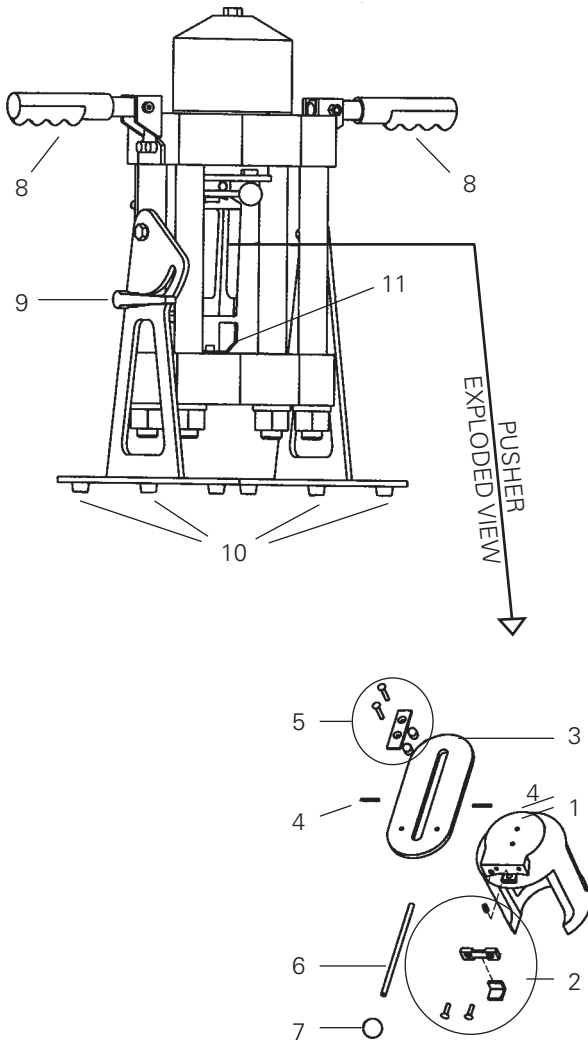

Item Number	Catalog Number	Description
1	T-480-P	Pusher
2	T-480-PSK	Pusher Stop Repair Kit (Includes pusher clip, 2 machine screws, pusher stop and spring)
3	T-480-SP	Slider Plate
4	140-05485-01	Roll Pin
5	T-480-SFK	Slide Flange Kit (Includes slide flange, 2 bushings and 2 machine screws)
6	T-480-SPR	Slide Pull Rod
7	T-480-SPK	Slide Pull Knob
8	140-06601	Vinyl Grip
9	T-480-TBK	Tilt Bracket Knob
10	140-06894	Foot Pad
11	T-480-69	Tool Locator Bracket
#	T-480-16	10,000 PSI replacement hose assembly for 480-HP
#	T-480-17	10,000 PSI replacement hose assembly for T-480-TA and T-480-EP
#	T-480-18	10,000 PSI replacement hose assembly for 480-AH
#	140-06906	Hydraulic Quick Coupler used with the T-480-TA and T-480-EP System
#	T-480-3	Turbo Air/Hydraulic replacement pump for T-480-TA System
#	T-481-110	Electric replacement pump for T-480-EP System
#	T-480-2	Hand replacement pump for T-480-HP System
#	T-482-2	Air/Hydraulic replacement pump for T-480-AH System
#	W-EQCR-TE012-E	Shroud Decal
#	W-EQCR-TM013-E	Set-up and Operating Guide for T-480 System
#	E-EQCR-ME002-E	Instructional Video

Item not illustrated in parts breakdown.

Crimping Machines - Portable

ET1000 Portable Crimp Machine

ET1000 • Portable Crimp Machine



CAUTION

Refer to pages A-2 and A-3 and machine operator's manuals for safety information.



The completely PORTABLE ET1000 crimp machine boasts a broad crimp capability with an ease-of-use that is sure to please hose assemblers. With three power source options - air/hydraulic, hand, and electric - this portable machine can travel to the worksite. The machine comes equipped with a stand pre-drilled for mounting to a workbench or table-top.

The ET1000 Portable Crimp Machine is a mid-size machine positioned between the other two popular portable crimp machines (the T-460 and T-480).

Capacity

Coll-O-Crimp U series hose ends and applicable hoses in sizes 1/4" through 1-1/4"

Coll-O-Crimp Z Series hose ends and applicable hoses in sizes 1/4" through 1-1/4"

Coll-O-Crimp 430U Series hose ends and applicable hoses in sizes 3/8" through 3/4"

Mounting

Work bench or table top

Weight

70 lbs. (less pump)

Tooling

Standard Coll-O-Crimp collets and spacer rings. Uses the same tooling as the T-420 machine.

Pump Kits

(pump kits contain hose assembly and fittings to attach pump to machine)

ET1000PK-001
Hand Pump

ET1000PK-002,
Air/Hydraulic Pump

ET1000PK-003
110 Volt Electric Pump

Pump Only

(does not include hose assembly or fittings)

T-480-2
Hand Pump

T-482-2
Air/Hydraulic Pump

T-481-110
110 Volt Electric Pump

Ordering Options

ET1000-001	Basic machine (no pump)
ET1000-002	Machine with hand pump*
ET1000-003	Machine with air/hydraulic pump*
ET1000-004	Machine with 110 volt electric pump*

* Includes hose assembly and fittings to attach pump to machine.

Note: Collets and spacers not included in kits. Must be ordered separately. See pages N-26-32 for part numbers.

Note: ET1000AR-001 adapter die ring required to Crimp T-400 and ET400 series collets. Not included in kits and must be ordered separately.

Repair and replacement items

ET1000C-0001	Stand
ET1000C-0006	Pusher
ET1000AR-001	Adapter Ring
T-400-G	1.5 oz. Tube High Efficiency Teflon® Grease

Additional repair and replacement items are available. Refer to the owner's manual or contact Eaton for information.

Teflon® is a registered trademark of DuPont used under license by Eaton.

ET1000 • Portable Coll-O-Crimp Packages for Z-Series

-4 thru -16 (no -10), one-wire and two-wire

Package Number	ET1000-016	ET1000-017	ET1000-018
Power Source	Hand Pump	Air/Hydraulic	110V
Contents Press, Pump and Hose Assembly	ET1000-002	ET1000-003	ET1000-004
Adapter Ring	ET1000AR-001	ET1000AR-001	ET1000AR-001
Z-Series Collets*	ET1000TP-0001	ET1000TP-0001	ET1000TP-0001

* See page N-30

Crimping Machines - Portable

ET1000 Crimping Procedures

Note:

See Crimp Bulletin #W-HOOV-TM001-E2 for tooling specifications.

Crimping Procedures



Step 1

Slide the pusher to the back position.

Using the Collet/Spacer Ring Selector Chart, select the proper collet assembly and spacer ring.

Step 2A (for T-420 and ET420 Series Collets)

Lubricate the inside cone of the die ring and external surfaces of the collet assembly with a high-efficiency Teflon-based lubricant (T-400-G).

Insert the collet assembly into the base die ring.

Step 2B (for T-400 and ET400 Series Collets)

Lubricate the inside cone of the base die ring and the outside cone of the die ring adapter plate.

Place the die ring adapter plate into the base die ring.

Lubricate the external surfaces of collet assembly halves with a high-efficiency Teflon-based lubricant.

Insert the collet assembly into the die ring adapter plate.



Step 3

Insert the hose assembly through the bottom of the base die ring and between the two collet assembly halves. Align the fitting with the top of the collet halves as referenced on the Collet/Spacer Ring Selector Chart.



Step 4

Place the spacer ring in the appropriate position on top of the collet assembly (either flat-side up or flat-side down as referenced in the Collet/Spacer Ring Selector Chart).



Step 5

Pull the pusher forward into the detent holding position with the pusher positioning handle.

Step 6

Begin crimping by actuating the pump. **When the spacer ring bottoms out against the base die ring**, the crimping is complete.

Note:

Visually inspect the crimp and verify the correct crimp diameter and length.

Teflon® is a registered trademark of DuPont used under license by Eaton.

Crimping Machines - Stationary

Coll-O-Crimp T-400-17

 Refer to pages A-2 and A-3 and machine operator's manuals for safety information.

Shop Press Tooling Packages

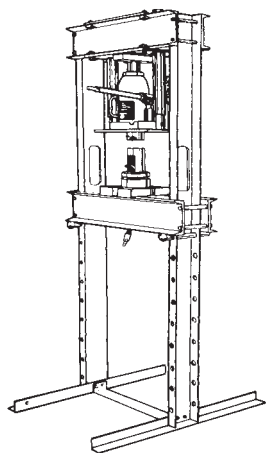

T-400-17 • Shop Press Tooling Package

The T-400-17 Shop Press Tooling Kit allows you to make factory-type hydraulic hose assemblies on your 25-ton shop press. With this minimum investment in equipment, and a nominal stock of packaged bulk hose and hose ends, you can begin to make Coll-O-Crimp hose assemblies in your own shop. This kit includes tooling to crimp 1/4" through 1" hose I.D. "U" Series hose ends. Additional tooling is available to crimp 5/8" and 1-1/4" I.D. sizes.

Included in kit:

Part Number	Description
T-400-2C	"U" Series Collet – 1/4"
T-400-3C	"U" Series Collet – 3/8"
T-400-4C	"U" Series Collet – 1/2"
T-400-5C	"U" Series Collet – 3/4"
T-400-6C	"U" Series Collet – 1"
T-400-8	Die Ring – 3/16" thru 1-1/4"
T-400-10	Spacer Ring – Black
T-400-11	Spacer Ring – Silver
T-400-17P	Pusher
W-EQCR-TD003-E	Shroud Decal
T-400-MSP	Instructions

WARNING

These kits are intended for use on shop presses not exceeding a 25-ton rating. Usage of presses exceeding this rating may result in damage to the pusher, causing metal fragments to spray which may result in serious bodily injury.

T-400-20A • Shop Press 757 "E" Series Tooling Package

The T-400-20A Shop Press 757 "E" Series Tooling Kit allows you to make factory-type air conditioning hose assemblies on your 25-ton shop press. With this minimum investment in equipment, and a nominal stock of packaged bulk hose and hose ends, you can begin to make Coll-O-Crimp hose assemblies in your own shop. This kit includes tooling to crimp all of the 757 'E' Series hose ends.

Included in kit:

Part Number	Description
T-400-114	757 "E" Series Collets
T-400-8	Die Ring Fits Collets 3/16" thru 1-1/4"
T-400-10	Spacer Ring – Black
T-400-17P	Pusher
W-EQCR-TD003-E	Shroud Decal
FS-3200	Label Set

Reference pages N-2 and N-3 for COC machine and tooling packages, and pages N-26 to N-30 for collet kits and spacer ring details.

Crimping Machines - Stationary

Coll-O-Crimp T-400



Refer to pages A-2 and A-3 and machine operator's manuals for safety information.

Coll-O-Crimp T-400



The Coll-O-Crimp I is the time-proven "Mini-Factory" that you can easily set up in your own shop. Fast, easy, compact, and various power sources available make this crimper versatile for even the smallest of workshops.

Capacity

3/16" I.D. 1-fiber braid through 1-3/8" I.D. 1 wire hose and 1-1/4" I.D. 2 wire hose

Mounting

Bench; FH-135X or C40X Cabinet

For cabinets see pages N-68-70

Size

16-1/4" high, 8" wide, 21-3/4" deep

Weight

113 lbs

Packages continued on next page.

Reference pages N-2 and N-3 for COC machine and tooling packages, and pages N-26 to N-30 for collet kits and spacer ring details.

Note:

25 ton (T-400-1 is C-O-C press only)

T-400 • Coll-O-Crimp I Packages for Z-Series

-4 thru -16 (no -10), one-wire and two-wire

Package Number	ET400-001	ET400-002	ET400-003
Power Source	220V	110V	Air/Hydraulic
Press	T-400-1	T-400-1	T-400-1
Hose Assembly	T-400-16	T-400-16	T-400-18
Pump	T-421U	T-421U-110	T-402-2
Die Ring	T-400-8	T-400-8	T-400-8
Z-Series Collets*	ET400TP-0001	ET400TP-0001	ET400TP-0001

* See page N-30 for details.

T-401 • C-O-C I and 220v Electric Pump Package

Includes one each of the following:

Catalog Number	Description
T-400	Press and tooling package
T-421U	Electric Pump (220v, 1 phase)

T-401-110 • C-O-C I and 110v Electric Pump Package

Includes one each of the following:

Catalog Number	Description
T-400	Press and tooling package
T-421U-110	Electric Pump (110v, 1 phase)

T-400 • Coll-O-Crimp I Package for U-Series*

Includes one each of the following:

Catalog Number	Description
T-400-1	Coll-O-Crimp Press, T-400-BB Switch, and T-400-M Instructions
T-400-2C	"U" Series Collet – 1/4"
T-400-3C	"U" Series Collet – 3/8"
T-400-4C	"U" Series Collet – 1/2"
T-400-5C	"U" Series Collet – 3/4"
T-400-6C	"U" Series Collet – 1"
T-400-10	Spacer Ring – Black
T-400-11	Spacer Ring – Silver
T-400-62	Spacer Ring – Yellow
T-400-16**	36" T-421U Pump to Press Hose Assembly
T-400-8	Die Ring

* Pump Required (sold separately): T-421U, T421U-110, T-402-2 or T-403-2 see pages N-33-35.

**Not supplied when ordering a T-402 or T-403 package.

T-402 • C-O-C I and Air/Hydraulic Pump Package

Includes one each of the following:

Catalog Number	Description
T-400	Press and tooling package/Less T-400-16
T-402-2	Air/Hydraulic Pump
T-400-18	108" Hose assembly and fittings

T-403 • C-O-C I and Hand Pump Package

Includes one each of the following:

Catalog Number	Description
T-400	Press and tooling package/Less T-400-16
T-403-2	Hand Pump
T-400-19	60" hose assembly and fittings

T-414 • C-O-C I and 12v Electric Pump Package

Includes one each of the following:

Catalog Number	Description
T-400	Press and tooling package
T-412	12-volt DC Electric Pump

Crimping Machines - Stationary

Coll-O-Crimp T-400 & T-407

T-400-9 • Crimp Locator

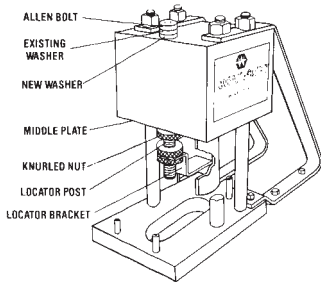

The T-400-9 allows you to make large volumes of hose assemblies by automatically aligning hose ends in proper crimp location.

Note:

Remove locator assembly when crimping bent tube ends.

Installation Procedure

- Remove the front Allen bolt using an Allen wrench or tool provided with kit.
- Add the washer provided with the kit to existing washer as shown and torque the bolt down to 75 ft.-lbs.
- Attach the locator post of the pre-assembled locator to the bottom of the middle plate and lock it in place with one of the knurled nuts.
- Align the dimples on the first assembly with top of collet to locate the crimp. Drop the locator bracket down to rest on top of the

hose end. Lock the bracket in position with remaining two knurled nuts. The locator now can be used, instead of dimples, to locate crimp accurately and consistently on the remaining hose ends of the same size and type.

T-400-1 Coll-O-Crimp I Repair and Replacement Items

Catalog Number	Description
T-400-B	Pusher Bolt
T-400-BB	Switch to interface T400-1 crimper to T421U pump or T-421U-110 pump
T-400-G	1.5 oz. Tube High Efficiency * Grease
T-400-K1	Seal Replacement Kit for T-400-1 press
W-EQCR-TD003-E	Shroud Decal
T-400-M	Instructions for T-400-1
T-400-S	Replacement press shroud with decals.
T-400-8	Die Ring
T-400-13	Replacement** collet cage for T-400 "U" Series collets, 1/4" and 3/8" sizes only, and 229 "P" Series
T-400-14	Replacement** collet cage for T-400 "U" Series collets with a "C" suffix, 1/2" through 1" only,
T-400-90	Replacement** collet cage for T-400 "E", 069 "E", and "E" Series collets with a "C" suffix.
T-432-15	Pusher
E-EQCR-ME002-E	Instructional Video

** 2 required for each collet

T-407-1 • Production Coll-O-Crimp Press



*Removal of crimp locator allows for crimping of 45° and 90° angle hose end configurations.

Reference pages N-2 and N-3 for COC machine and tooling packages, and pages N-26 to N-30 for collet kits and spacer ring details.

The T-407-1 Production Coll-O-Crimp, as its name implies, is at its best in the fast production of straight configuration hose end crimping. Taking advantage of the swiveling bracket which supports the crimper, tooling can be put in place and the press locked in at up to a 90° angle, facilitating quick hose end crimping. A crimp locator is included. When set to position, the crimp locator allows for a preset of the correct crimp location so hose assemblies can be built in volume, with accuracy and precision. The T-407-1 offers crimping capabilities of 3/16"-1-fiber braid through 1-3/8" I.D. 1-wire hose and 1-1/4" I.D. 2-wire hose.

Weight: (for press and pump) 198 lbs

Size Press: 16-1/4" high, 21-3/4" deep

Includes one each of the following:

Catalog Number	Description
T-400-M	Instructions
T-400-8	Die Ring
T-400-9	Crimp Locator
T-400-19	60" hose assembly and fittings

T-407 • Production Coll-O-Crimp Package

The T-407 comes with a high-volume pump and a foot switch.

Size Pump: 26" high, 18" wide
(Pump is wired for 220v, 1 phase)

Includes one each of the following:

Catalog Number	Description
T-407-1	Production C-O-C Press
T-433	Two-Stage Piston Pump and foot switch

Note: The T-433 pump which is shipped as part of the T-407 Production Coll-O-Crimp System.

Crimping Machines - Stationary

Coll-O-Crimp Super I, T-420



Refer to pages A-2 and A-3 and machine operator's manuals for safety information.

T-420 • Coll-O-Crimp Super I Packages for Z-Series

-4 thru -16 (no -10), one-wire and two-wire

Package Number	ET420-002	ET420-003
Power Source	220V	110V
Contents Press	T-420-1	T-420-1
Hose Assembly	T-410-22	T-410-22
Pump	T-421U	T-421U-110
Adapter Ring	T-420-25	T-420-25
Z-Series Collets*	ET420TP-0001	ET420TP-0001

* See page N-30

T-420-N • Coll-O-Crimp Super I - 220V Package

T-420N-110 • Coll-O-Crimp Super I - 110V Package

Includes one each of the following (with respective pump):

Catalog Number	Description
T-420-1	Coll-O-Crimp Super I Press and T-420-M Instructions
T-421U or T-421U-110	220v or 110V Electric Pump
T-400-2C	"U" Series Collet- 1/4"
T-400-3C	"U" Series Collet- 3/8"
T-400-4C	"U" Series Collet- 1/2"
T-400-5C	"U" Series Collet- 3/4"
T-400-6C	"U" Series Collet- 1"
T-400-10	Spacer Ring- Black
T-400-11	Spacer Ring- Silver
T-400-62	Spacer Ring Yellow
T-410-22	36" Pump to Press Hose Assembly
T-420-25	Adapter Ring for T-400 Series Collets
T-420-4CN	430 "U" Series Collet- 1/2"
T-420-5CN	430 "U" Series Collet- 3/4"
T-420-6CN	430 'U' Series Collet- 1"
T-420-7CN	430 'U' Series Collet- 1-1/4"



The Coll-O-Crimp Super I is a versatile machine ideal for your shop, factory, construction, and mine locations. Big capacity combined with lever-activated crimping gives you wide coverage and a quick and simple way to make factory-quality hose assemblies.

Capacity

3/16" I.D. 1 fiber braid through 1-1/4" 6 spiral hose*; for hose other than 4 and 6 spiral, conversion tooling is required. See page N-36 for details.

*Will not crimp 4SP/6SP ends

Mounting

Bench or C-40X cabinet.

See pages N-68-70 for cabinet (not included).

Size

22" high, 10" wide, 20-1/2" deep

Weight

210 lbs.



CAUTION

The Coll-O-Crimp power source has the pressure relief valve set at 4000 to 4200 PSI. Damage to the press will result if higher pressures are used and warranty will be voided.

ET420-004 Coll-O-Crimp I - 220V Package

ET420-005 Coll-O-Crimp I - 110V Package

Both Packages include the following (with respective pump):

Catalog Number	Description
T-420-1	Coll-O-Crimp Super I
T-421U or T-421U-110	220v or 110V Electric Pump
ET400DC-M150S	'Z' Series Collet- 1/4"
ET400DC-M195S	'Z' Series Collet- 3/8"
ET400DC-M230S	'Z' Series Collet- 1/2"
T-420-85C	'Z' Series Collet- 5/8"
T-420-86C	'Z' Series Collet- 3/4"
ET420DC-M380S	'Z' Series Collet- 1"
T-400-10	Spacer Ring- Black
T-400-62	Spacer Ring- Yellow
T-420-80R	Spacer Ring- Black/White
ET1000SR-M190D	Spacer Ring- Light Green
ET420SR-M255A	Spacer Ring- Black/Grey
ET420SR-M495A	Spacer Ring- Brown
T-410-22	36" Pump to Press Hose Assembly
T-420-25	Adapter Ring for T-400 Series Collets
T-420-4CN	430 'U' Series Collet- 1/2"
T-420-5CN	430 'U' Series Collet- 3/4"
T-420-6CN	430 'U' Series Collet- 1"
T-420-7CN	430 'U' Series Collet- 1-1/4"

Crimping Machines - Stationary

Coll-O-Crimp ET4001



The ET4001 is ideal for factory, high performance machine operations, construction and mine locations. This machine offers the capabilities of crimping all of the crimp-style hose ends Weatherhead offers. With this coverage, this heavy-duty crimper can handle all of your crimping needs.

Capacity

3/16" I.D. 1-fiber braid through 2" 6-spiral hose.

Mounting

Bench or Coll-O-Cart (FF91042)

Size

29" high, 12" wide, 21" deep

Weight

550 lbs.

Reference pages N-2 and N-3 for COC machine and tooling packages, and pages N-26 to N-30 for collet kits and spacer ring details.

Note:

Seal kits for T-410, T-440, ET4000 and ET4001 are not sold separately. Crimpers must be sent in and torqued by Weatherhead.

Note:

ET4000AR-002 Adapter Die Ring required for -20, -24, and -32 size 4SP and 6SP series collets.

ET4001-004 • Coll-O-Crimp Package

Includes one each of the following:

Catalog Number	Description
ET4001-002	ET4001 Press, Operating Instructions and 140-06741 Switch
ET4001P-001	220v Single Phase Electric Pump
T-410-22	36" Pump to Press Hose Assembly

ET4001-006 • Coll-O-Crimp Package

Includes one each of the following:

Catalog Number	Description
ET4001-004	Press and Pump Package
T-410-4CN	430 'U' Series Collet – 1/2" I.D.
T-410-5CN	430 'U' Series Collet – 3/4" I.D.
T-410-6CN	430 'U' Series Collet – 1" I.D.
T-410-7CN	430 'U' Series Collet – 1-1/4" I.D.
T-410-8N	430 'U' Series Collet – 1-1/2" I.D.
T-410-9N	430 'U' Series Collet – 2" I.D.

ET4001-010 • Coll-O-Crimp Package

Includes one each of the following:

Catalog Number	Description
ET4001-004	Machine 220V Pump & Assembly
ET4000AR-002	Adapter Ring
ET4000SR-M215A	Black/Magenta Spacer Ring
ET4000SR-M180A	Black/Purple Spacer Ring
T-440-80R	Black/White Spacer Ring
ET4000DC-6S32	2" 6SP Series Collet
ET4000DC-6S24	1-1/2" 6SP Series Collet
ET4000DC-6S20	1-1/4" 6SP Series Collet
ET4000DC-4S16	1" 4SP Series Collet
ET4001DC-4S12	3/4" 4SP Series Collet

Crimping Machines - Stationary

Repair and Replacement Parts



Refer to pages A-2 and A-3 and machine operator's manuals for safety information.

Coll-O-Crimp Super I T-420 Repair and Replacement Items

Catalog Number	Description	Catalog Number	Description
T-420-1M	Micro-Switch for T-420-1 Press	T-420-G	Linkage Assembly
T-420-28	Tool Locator Bracket	T-420-2R	Rack
T-420-B	Pusher Bolt and Washers	T-420-2K	Pinion Shaft Assembly (incl'd T-420-2G, T-420-2R and T-420-2S)
W-EQCR-TE006-E	Shroud Decal	T-420-2S	Replacement Pinion Gear Shaft
T-420-H	Handle	T-420-2G	Replacement Pinion Gear
T-420-L	Light Bulb	T-400-G	1.5 oz. Tube High Efficiency Teflon® Grease
T-420-LA	Light Assembly	T-401-1BC	Threaded Breather Cap for T-421U Pump
T-420-LS	Light Switch	T-421U-BC	Twist Lock Breather Cap for T-421U Pump
W-EQCR-TM004-E	Instructions for T-420-1	140-06745	Pusher Wear Plates includes (1) Left and (1) Right
T-420-P	Pusher Set (2) with Wear Plates and Screws	140-06748	Pusher Wear Plates Screws (1)
T-420-S	Press Shroud with Decals		See pages N-33-35 for replacement pumps.
T-420-26	Insert – Base Plate		Reference pages N-2 and N-3 for COC machine and tooling packages, and pages N-26 to N-30 for collet kits and spacer ring details.
E-EQCR-ME002-E	Instructional Video		Refer to pages A-2 and A-3 and machine operator's manuals for safety information.

Teflon® is a registered trademark of DuPont used under license by Eaton.



T-420



ET4000



ET4001



FF91042
Coll-O-Cart

Repair and Replacement Items:

Catalog Number	Description
T-410-26	Base Plate Insert for T-410-1 Machine
T-410-26R	Base Plate Insert for T-440-1 Machine
ET4000AR-001	Base Plate Insert for ET4000 Machine
T-410-28	Tool Locator Bracket Kit for the T-410-1 and T-440-1 Machine
ET4000TP-0001	Tool Locator Bracket Kit for the ET4000 Machine
T-410-P	Pusher Set for T-410-1, T-440-1 and ET4000 Machines (includes wear plates)
T-410-1M	Microswitch for T-410-1, T-440-1 and ET4000 Machine
T-421-FP	4 Prong Female Electrical Outlet
T-400-G	1.5 oz. Tube Teflon® Grease
T-410-BB	Pump Switch for T-410-1 Machine
140-06741	Pump Switch for the T-440-1 and ET4000 Machines
ET4000TP-002	Wear Plate Kit for T-410-1, T-440-1 and ET4000 Machines (Includes both halves plus screws)
W-EQCR-TE007-E	Shroud Decal for T-440-1 Machine
W-EQCR-TE014-E	Shroud Decal for ET4000 Machine
W-EQCR-TE010-E	Owner's Manual for T-440-1 Machine
W-EQCR-TE002-E	Owner's Manual for ET4000 Machine
W-EQCR-TM022-E	Owner's Manual for ET4001 Machine
E-EQCR-ME002-E	Instructional Video
ET4001-011	ET4000 Retrofit: Lengthen tie rods & install new valve & 3-way switch
ET4001-012	ET4000 Retrofit: Lengthen tie rods
ET4001-013	ET4000 Retrofit: Install new valve & 3-way switch
ET4001-014	ET4000 Retrofit: Kit for field installation of new valve & 3-way switch
ET4001C-0017	Gooseneck lamp, magnetic mount
FF91042	Coll-O-Cart for ET4001 or T-420

Teflon® is a registered trademark of DuPont used under license by Eaton.

Crimping Machines - Variable

ET4020

ET4020



The ET4020 is a benchtop crimp machine that crimps hydraulic hose assemblies up to 1-1/4" braided and four spiral wire hose. This machine has programmable electronic keypads with 10 presets. These keypads simplify the hose crimping operation by allowing the machine operator to enter a pre-determined setting for a specific hose type and size. The 10 most often used crimp settings can be stored for one-touch retrieval. The machine will automatically crimp to the exact crimp diameter required for that hose type and size. The electronic crimp machine settings eliminate the need

for spacers or shims in the crimping operation.

Features

- Electronic Programmable Keypad
- 10 Crimp Diameter Presets
- Individual die cages for each hose size

Benefits

- Easy to electronically enter crimp setting
- Can pre-program 10 most popular crimp settings
- Die cages easily slip in and out of machine

Dimensions

12.75" Wide x 25.75" Deep x 28.5" High

Electrical Requirements

115 volt standard, 230 volt available

Weight

238 lbs.

Hose Ends:

Z series and 430U series

Tooling and Crimp Machine Packages

Part Number	Description	Ends Crimped	430U Sizes Crimped	ET4020TP-0003 Z & 430U Tooling Only	ET4020-006 Z & 430U Tooling & Crimper
ET4020-115	Crimp Machine (115V)			0	1
W-EQCR-TM020-E	Operator's Manual			0	1
FT1380-200-M150	Die Cage	Z		1	1
FT1380-200-M180	Die Cage	Z		1	1
FT1380-200-M210	Die Cage	Z and 430U	-6	1	1
FT1380-200-M240	Die Cage	Z		1	1
FT1380-200-M280	Die Cage	Z and 430U	-8 and -10	1	1
FT1380-200-M320	Die Cage	Z and 430U	-12	1	1
FT1380-200-M370	Die Cage	Z		1	1
FT1380-200-M420	Die Cage	Z and 430U	-16	1	1
FT1381-200-M465	Die Cage	Z and 430U	-20	1	1

Note: Also available: ET4020-230 (230V) machine.
ET1380-2-4 die holders. Consists of 4 plates that attach to the sides of the machine and can hold up to eight die cages. Mounting hardware is included.

Crimping Machines - Variable

ET4040



ET4040

The ET4040 crimp machine comes with a base so no benchtop is needed. The ET4040 will crimp up to 2" braided and six heavy-spiral hydraulic hose assemblies. This machine has programmable electronic keypads with 10 presets. These keypads simplify the hose crimping operation by allowing the machine operator to enter a pre-determined setting for a specific hose type and size. The 10 most often used crimp settings can be stored for one-touch retrieval. The machine will automatically crimp to the exact crimp diameter required for that hose type and size.

The electronic crimp machine settings eliminate the need for spacers or shims in the crimping operation.

Features

- Electronic Programmable Keypad
- 10 Crimp Diameter Presets
- 2-piece Master die cage
- Durable, lightweight and low cost die inserts for each size
- Magnetic handle

Benefits

- Easy to electronically enter crimp setting
- Can pre-program 10 most popular crimp settings
- Die sets easily mount into fixed master die cage

- Top half of master cage slips in and out to allow easy loading of elbows
- Tool mounted die inserts are safer and cleaner
- Magnetic handle firmly connects & releases die inserts with a quick twist

Dimensions

29" Wide x 28" Deep x 45" High

Electrical Requirements

115 volt standard, 230 volt available

Weight

825 lbs.

Hose Ends:

Z series, 430U series and 4SP/6SP series

ET4040 Tooling And Crimp Machine Packages (Qty per package)

Package Part Number	ET4040TP-0004	ET4040-007	ET4040TP-0005	ET4040-008	ET4040TP-0006	ET4040-009		
Part Number	Description	Ends Crimped	Z & 430U Tooling Only	Z & 430U Tooling & Crimper	4SP/6SP Tooling Only	4SP/6SP Tooling & Crimper	Z, 430U, & 4SP/6SP Tooling Only	Z, 430U, & 4SP/6SP Tooling & Crimper
ET4040-115	Crimp Machine (115V)			1		1		1
W-EQCR-TM021-E	Operator's Manual			1		1		1
ET1295-001	Master Die Cage (2-Piece)			1		1		1
ET1295TP-0001	Handle To Capture Die Inserts			1		1		1
ET1295C-0027	Hanging Rack for Die Inserts			2		2		2
ET1295DC-M150S	Die Inserts (8 Pieces)	Z	1	1			1	1
ET1295DC-M180S	Die Inserts (8 Pieces)	Z	1	1			1	1
ET4040DC-M210S	Die Inserts (8 Pieces)	Z and 430U	1	1			1	1
ET1295DC-M240S	Die Inserts (8 Pieces)	Z	1	1			1	1
ET4040DC-M280S	Die Inserts (8 Pieces)	Z and 430U	1	1			1	1
ET4040DC-M320S	Die Inserts (8 Pieces)	Z and 430U	1	1			1	1
ET1295DC-M370S	Die Inserts (8 Pieces)	Z	1	1			1	1
ET4040DC-M420S	Die Inserts (8 Pieces)	Z and 430U	1	1			1	1
ET4040DC-M465S	Die Inserts (8 Pieces)	Z and 430U	1	1			1	1
ET4040DC-M520S	Die Inserts (8 Pieces)	430U	1	1			1	1
ET1295DC-M550S	Die Inserts (8 Pieces)	Z	1	1			1	1
ET4040DC-M570S	Die Inserts (8 Pieces)	Z and 430U	1	1			1	1
ET4040DC-M690S	Die Inserts (8 Pieces)	Z and 430U	1	1			1	1
ET1295DC-82S	Die Inserts (8 Pieces)	4SP12			1	1	1	1
ET1295DC-46S	Die Inserts (8 Pieces)	4SP16			1	1	1	1
ET1295DC-14S	Die Inserts (8 Pieces)	4SP20			1	1	1	1
ET1295DC-20S	Die Inserts (8 Pieces)	4SP24			1	1	1	1
ET1295DC-23S	Die Inserts (8 Pieces)	4SP32			1	1	1	1
ET1295DC-15S	Die Inserts (8 Pieces)	6SP20			1	1	1	1
ET1295DC-16S	Die Inserts (8 Pieces)	6SP24			1	1	1	1
ET1295DC-21S	Die Inserts (8 Pieces)	6SP32			1	1	1	1
MSDS Sheet	Hydraulic Fluid			1		1		1
MSDS Sheet	Never Seez			1		1		1
FT1289-3-30	Shipping Crate			1		1		1
ET4040-230	Crimp Machine(230V, 50/60H) (optional)							

ET4040 Master Die Cage and Tooling



Master Die Cage

Die Inserts

Handle to capture die inserts

A - ET1295C-0027 Machine Mounted Die Insert Holder Rack (standard)

B - ET1295C-0029 Table-Top Die Insert Holder Rack (optional)

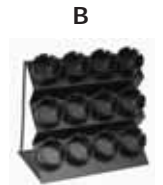
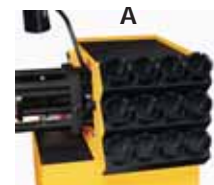

Coll-O-Crimp Collet Kits

Collet Kits



The Eaton tools listed are offered in kits for any given hose type, or collets and tools can be purchased individually by catalog number.

Refer to Crimp Bulletin # W-HOOV-TM001-E2 for proper spacer rings.



Refer to pages A-2 and A-3 and machine operator's manuals for safety information.

Note:

See Crimp Bulletin #W-HOOV-TM001-E2 for proper Collet selection for hose style and size desired.

Note:

Collets may be ordered individually.

T-400-30 'E' Series Collet Kit

This kit can be used with the following C-O-C systems: T-400-1, T-420-1, T-440-1, ET4000, T-460, T-462, T-465, and T-480.

Kit includes one each of the following:

Catalog Number	Description
T-400-113C	Collet – 3/16" (H243 only)
T-400-31C	Collet – 1/4"
T-400-32C	Collet – 5/16"
T-400-33C	Collet – 3/8"

Spacer Rings not included in T-400-30 kit.

Catalog Number	Description
T-400-34C	Collet – 1/2"
T-400-35C	Collet – 3/4"
T-400-36C	Collet – 1"
FS-1200	Label Set/Layout Guide

T-400-66 069 'E' Series Collet Kit

This kit can be used with the following C-O-C systems: T-400-1, T-420-1, T-440-1, ET4000, T-460, T-462, T-465, and T-480.

Kit includes one each of the following:

Catalog Number	Description
T-400-54C	Collet – 3/16"
T-400-55C	Collet – 1/4"
T-400-56C	Collet – 5/16"
T-400-57C	Collet – 13/32"
T-400-58C	Collet – 1/2"

Spacer Rings not included in T-400-66 kit.

Catalog Number	Description
T-400-59C	Collet – 5/8"
T-400-60C	Collet – 7/8"
T-400-61C	Collet – 1-1/8"
T-400-70	Collet – 1-3/8"
FS-1500	Label Set/Layout Guide

T-400-67 'U' Series Collet Kit

This kit can be used with the following C-O-C systems: ET1000, T-400-1, T-420-1, T-440-1, ET4000, T-460, T-462, T-465, T-480, and ET1000.

Kit includes one each of the following:

Catalog Number	Description
T-400-2C	Collet – 1/4"
T-400-3C	Collet – 3/8"
T-400-4C	Collet – 1/2"
T-400-64C	Collet – 5/8"

Spacer Rings not included in T-400-67 kit.

Catalog Number	Description
T-400-5C	Collet – 3/4"
T-400-6C	Collet – 1"
T-400-12	Collet – 1-1/4"
FS-1100	Label Set/Layout Guide

T-400-137 229 'P' Series Collet Kit

This kit can be used with the following C-O-C systems: T-400-1, T-420-1, T440-1, ET4000, T460, T-462, T-465, and T-480.

Kit includes one each of the following:

Catalog Number	Description
T-400-80C	Collet – 3/16"
T-400-82C	Collet – 13/32"

Spacer Rings not included in T-400-137 kit.

Catalog Number	Description
T-400-81C	Collet – 5/16"
T-400-83C	Collet – 1/2"

T-400-104 338 'P' Series Collet Kit

This kit can be used with the following C-O-C systems: T-400-1, T-420-1, T-440-1, ET4000, T-460, T-462, T-465, and T-480.

Kit includes one each of the following:

Catalog Number	Description
T-400-102C	Collet – 3/8"
T-400-103C	Collet – 1/2"

Spacer Rings not included in T-400-104 kit.

Catalog Number	Description
FS-2900	Label Set

Coll-O-Crimp Collet Kits

Collet Kits



Note:
See Crimp Bulletin # W-HOOV-TM001-E2 for proper Collet selection for hose style and size desired.

 Refer to pages A-2 and A-3 and machine operator's manuals for safety information.

Note:
Collets may be ordered individually.

T-400-114 757 'E' Series Collet Kit

This kit can be used with the following C-O-C systems: T-400-1, T-420-1, T-440-1, ET4000, T-460, T-462, T-465, and T-480.

Kit includes one each of the following:

Catalog Number	Description	Catalog Number	Description
T-400-105C	Collet – 5/16"	T-400-106C	Collet – 13/32"
T-400-107C	Collet – 1/2"	T-400-108C	Collet – 5/8"

Spacer Rings not included in T-400-114 kit.

T-400-129 336 'E' Series Collet Kit

This kit can be used with the following C-O-C systems: T-400-1, T-420-1, T-440-1, ET4000, T-460, T-462, and T-480.

Kit includes one each of the following:

Catalog Number	Description	Catalog Number	Description
T-400-120C	Collet – 3/16"	T-400-123C	Collet – 1/2"
T-400-122C	Collet – 3/8"	FS-3500	Label Set
T-400-121C	Collet – 1/4"		

* For size 3/4" order T-420-15C. For 1" size order T-420-16C. For use with T-420-1 and T480-1 only.

T-410-70 470 'E' Series Collet Kit

This kit can be used with the following C-O-C systems: T-410-1, T-440-1, ET4000 ONLY.

Kit includes one each of the following:

Catalog Number	Description	Catalog Number	Description
T-470-8C	Collet – 1/2"	T-470-24	Collet – 1-1/2"
T-470-12C	Collet – 3/4"	T-440-32*	Collet – 2"
T-470-16C	Collet – 1"	FS-1800	Label Set/Layout Guide
T-470-20	Collet – 1-1/4"		

*-32 size requires T-440 or ET4000 system.

T-410-80 430 'U' Series No Skive Collet Kit

This kit can be used with the following C-O-C systems: T-440-1, and ET4000 ONLY.

Kit includes one each of the following:

Catalog Number	Description	Catalog Number	Description
T-410-4CN	Collet – 1/2"	T-410-8N	Collet – 1-1/2"
T-410-5CN	Collet – 3/4"	T-410-9N	Collet – 2"
T-410-6CN	Collet – 1"	FS-3100	Label Set
T-410-7CN	Collet – 1-1/4"		

T-420-70 470 'E' Series Collet Kit

This kit can be used with the following C-O-C systems: T-420-1, and T-480.

Kit includes one each of the following:

Catalog Number	Description	Catalog Number	Description
T-420-8C	Collet – 1/2"	T-420-11	Collet – 1-1/4"
T-420-9C	Collet – 3/4"	FS-1800	Label Set
T-420-10C	Collet – 1"		

T-420-80 430 'U' Series No Skive Collet Kit

This kit can be used with the following C-O-C systems: T-420-1, and T-480

Kit includes one each of the following:

Catalog Number	Description	Catalog Number	Description
T-420-4CN	Collet – 1/2"	T-420-7CN	Collet – 1-1/4"
T-420-5CN	Collet – 3/4"	FS-3100	Label Set
T-420-6CN	Collet – 1"		

Coll-O-Crimp Collet Kits

Collet Kits



Note:

See Crimp Bulletin # W-H00V-TM001-E2 for proper Collet selection for hose style and size desired.



Refer to pages A-2 and A-3 and machine operator's manuals for safety information.

Note:

Collets may be ordered individually.

T-480-80 'U' and 430 'U' Series Collet Kit

This kit can be used with the following C-O-C systems: T-420-1, and T-480 ONLY.

Kit includes one each of the following:

Catalog Number	Description
T-400-2C	Collet – 1/4" 'U' Series
T-400-3C	Collet – 3/8" 'U' Series
T-400-4C	Collet – 1/2" 'U' Series
T-400-5C	Collet – 3/4" 'U' Series
T-400-6C	Collet – 1" 'U' Series
T-400-10	Spacer Ring - Black
T-400-11	Spacer Ring - Silver

Catalog Number	Description
T-400-62	Spacer Ring - Yellow
T-420-25	Adapter Ring for T-400 Series Collets
T-420-4CN	Collet – 1/2" 430 'U' Series
T-420-5CN	Collet – 3/4" 430 'U' Series
T-420-6CN	Collet – 1" 430 'U' Series
T-420-7CN	Collet – 1-1/4" 430 'U' Series

Refer to Crimp Bulletin # W-H00V-TM001-E2 for proper spacer rings.

069 'E' Series Collet Size 32

For use with: T-440, and ET4000 ONLY.

Catalog Number	Description
T-410-71C	Collet – 1-13/16"

265 'P' Series Collets

For use with: T-400, T-420, T-460, T-462, T-465, T-440, ET4000, T-480.

Kit includes one each of the following:

Catalog Number	Description
T-400-2C	Collet – 1/4" and 3/8"
T-400-3C	Collet – 1/2"

Catalog Number	Description
T-400-64C	Collet – 5/8"

4SP & 6SP Series Collets

For use with: T-440. and ET4000 ONLY.

Kit includes one each of the following:

Catalog Number	Description
ET4000DC-4S12	Collet – 3/4"
ET4000DC-4S16	Collet – 1"
ET4000DC-4S20*	Collet – 1-1/4"
ET4000DC-4S24*	Collet – 1-1/2"
ET4000DC-4S32*	Collet – 2"

Catalog Number	Description
ET4000DC-6S20*	Collet – 1-1/4"
ET4000DC-6S24*	Collet – 1-1/2"
ET4000DC-6S32*	Collet – 2"

Qualified on ET4000 machine only.
*Requires ET4000AR-002 base adapter bowl.

Coll-O-Crimp Collet Kits

Collet Kits



Refer to pages A-2 and A-3 and machine operator's manuals for safety information.



Note:

See Crimp Bulletin # W-HOOV-TM001-E2 for proper Collet selection for hose style and size desired.

Note:

Collets may be ordered individually.

T-410-27 • Conversion Kit

For use if you have collets used on our smaller T-400 Coll-O-Crimp I and you are upgrading to an ET4000.

Example:

If you desire to crimp hose other than 4- or 6-spiral hose, you will need the T-410-25 Adapter Die Ring which is included in the conversion kit. This ring allows the use of standard Coll-O-Crimp I tooling, in the Coll-O-Crimp II Plus and ET4000 Press.

If you have a Coll-O-Crimp II Plus or ET4000 press and would like to be able to crimp 'U' Series hose ends, order T-410-27 conversion kit and T-400-67 for all the collets. Collets and tools may also be purchased individually by catalog number.

Kit includes one each of the following:

Catalog Number	Description
T-410-10	Spacer Ring Black
T-410-11	Spacer Ring Silver
T-410-25	Adapter Die Ring
T-410-41	Spacer Ring Yellow

Adapter Die Rings

Catalog Number	Description
T-400-8	Adapter Die Ring for T-400 Collets (T-400-1 Press)
T-410-25	Adapter Die Ring for T-400 Collets (ET4000, T-440-1 Presses)
T-420-25	Adapter Die Ring for T-400 Collets (T-420-1 Press and T-480 Packages)
ET1000AR-001	Adapter Die Ring for T-400 Collets (ET1000 Press)
ET4000AR-002	Adapter Die Ring for -20, -24 & -32 4SP/6SP Ends (ET4000 Press)

Collet Cage Replacements

Catalog Number	Description
T-400-13	Replacement collet cages for: T-400-2C, T-400-3C, T-400-80C, T-400-81C, T-400-82C, T-400-83C, T-400-100C, T-400-101C
T-400-14	Replacement collet cages for: T-400-4C, T-400-5C, T-400-6C, T-400-64C, T-400-105C, T-400-106C, T-400-107C, T-400-108C, T-400-109C, T-400-110C, T-400-111C, T-400-120C, T-400-121C, T-400-122C, T-400-123C
T-400-15	Replacement collet cages for: T-400-31C, T-400-32C, T-400-46C, T-400-47C, T-400-102C, T-400-103C, T-400-113C
T-400-90	Replacement collet cages for: T-400-33C, T-400-34C, T-400-35C, T-400-36C, T-400-48C, T-400-49C, T-400-54C, T-400-55C, T-400-56C, T-400-57C, T-400-58C, T-400-59C, T-400-60C, T-400-61C
T-420-14NS	Replacement collet cages for: T-410-4CN, T-410-5CN, T-410-6CN, T-410-7CN, T-410-72CN, T-410-73CN, T-420-4CN, T-420-5CN, T-420-6CN, T-420-7CN
T-420-14	Replacement collet cages for: T-410-4C, T-410-5C, T-410-6C, T-410-7C, T-410-8C, T-420-4C, T-420-5C, T-420-6C, T-420-7C, T-420-8C, T-420-9C, T-420-10C, T-420-30C, T-470-8C, T-470-12C, T-470-16C

Note:

These items are half cages. Order 2 for complete cage.

Die Ring Lubricant

Catalog Number	Description
T-400-G	1.5 oz. Tube High Efficiency Grease

Note:

See page N-31 for individual collet part numbers.



Refer to pages A-2 and A-3 and machine operator's manuals for safety information.

ET400TP-0001 Crimp Kit for T-400 Crimper

(For Braided Hose sizes -4 thru 16 (no -10) one-wire and two-wire)

Collet Color	Spacer Ring P/N	Spacer Ring
ET400DC-M150S	ET1000SR-M100A	Purple
ET400DC-M195S	T-400-62	Yellow
ET400DC-M230S	T-400-46R	Black/Tan
ET400DC-M245S	ET1000SR-M190D	Lt. Green
ET400DC-M295S	T-400-37	Green
ET400DC-M375S	T-400-10	Black
	ET400SR-002	Black/Green
	T-400-48R	Black/Orange
	ET400SR-003	Black/Purple
	T-400-49R	Black/Silver
	T-400-112	Tan

Note: Also includes 2 each of ET400AR-001 Adapter Ring.

ET420TP-0001 Crimp Kit for T-420 Crimper

(For Braided Hose sizes -4 thru 16 (no -10) for one-wire and two-wire)

Collet Color	Spacer Ring P/N	Spacer Ring
ET400DC-M150S	ET1000SR-M100A	Purple
ET400DC-M195S	T-400-62	Yellow
ET400DC-M230S	T-400-46R	Black/Tan
T-420-86C	ET1000SR-M190D	Lt. Green
ET420DC-M380S	T-400-37	Green
	T-400-10	Black
	T-400-112	Tan
	ET420SR-M495A	Gray
	ET420SR-M255A	Black/Silver
	T-420-29	Orange
	T-420-82R	Black/Blue

ET440TP-0001 Crimp Kit for T-440, ET4000 and ET4001 Crimpers

(For Braided Hose sizes -4 thru 16 (no -10) for one-wire and two-wire)

Collet Color	Spacer Ring P/N	Spacer Ring
ET400DC-M150S	ET4000SR-M100A	Purple
ET400DC-M195S	T-410-41	Yellow
ET400DC-M230S	T-440-78R	Black/Tan
T-440-86C	ET4000SR-M190D	Lt. Green
ET4000DC-M380S	T-410-39	Green
	T-410-10	Black
	T-410-42	Tan
	ET4000SR-M405A	Gray
	ET4000SR-M215A	Black/Magenta
	T-410-93	Orange
	T-440-82R	Black/Blue

ET460TP-0001 Crimp Kit for T-460 Series Crimper

(For Braided Hose sizes -4 thru 8 one-wire)

Collet Color	Spacer Ring P/N	Spacer Ring
ET400DC-M150S	ET1000SR-M100A	Purple
ET400DC-M195S	T-400-62	Yellow
ET400DC-M230S	T-400-46R	Black/Tan
	ET1000SR-M190D	Lt. Green
	T-400-37	Green
	T-400-10	Black
	T-400-112	Tan

ET1000TP-0001 Crimp Kit for ET1000 Crimper

(For Braided Hose sizes -4 thru 16 (no -10) for one-wire and two-wire)

Collet Color	Spacer Ring P/N	Spacer Ring
ET400DC-M150S	ET1000SR-M100A	Purple
ET400DC-M195S	T-400-62	Yellow
ET400DC-M230S	T-400-46R	Black/Tan
T-420-86C	ET1000SR-M190D	Lt. Green
ET420DC-M380S	T-400-37	Green
	T-400-10	Black
	T-400-112	Tan
PUSHER EXTENSION	ET420SR-M495A	Gray
ET1000C-0012	ET420SR-M255A	Black/Silver
	T-420-29	Orange
	T-420-82R	Black/Blue
	T-480-68	Blue

ET480TP-0001 Crimp Kit for T-480 Crimper

(For Braided Hose sizes -4 thru 16 (no -10) for one-wire and two-wire)

Collet Color	Spacer Ring P/N	Spacer Ring
ET400DC-M150S	ET1000SR-M100A	Purple
ET400DC-M195S	T-400-62	Yellow
ET400DC-M230S	T-400-46R	Black/Tan
T-420-86C	ET1000SR-M190D	Lt. Green
ET420DC-M380S	T-400-37	Green
	T-400-10	Black
	T-400-112	Tan
	ET420SR-M495A	Gray
	ET420SR-M255A	Black/Silver
	T-420-29	Orange
	T-420-82R	Black/Blue



Note:
See Crimp Bulletin #W-HOOV-TM001-E2 for proper Collet selection for hose style and size desired.

 Refer to pages A-2 and A-3 and machine operator's manuals for safety information.

'Z' Series Collets

For use with: T-400, T-410, T-420, T-460, T-462, T-465, T-440, T-480, ET1000, ET4000 and ET4001.

Part Number	Description
ET400DC-M150S	Collet – 1/4"
ET400DC-M195S	Collet – 3/8"
ET400DC-M230S	Collet – 1/2"

'Z' Series Collets

For use with: T-400.

Part Number	Description
ET400DC-M245S*	Collet – 5/8"
ET400DC-M295S*	Collet – 3/4"
ET400DC-M375S*	Collet – 1"

* Requires two ET400AR-001 base halves. Sold separately.

'Z' Series Collets

For use with:
T-420, T-480, and ET1000.

Part Number	Description
T-420-85C	Collet – 5/8"
T-420-86C	Collet – 3/4"
ET420DC-M380S	Collet – 1"
ET420DC-M480S	Collet – 1-1/4" 2-wire (20Z series)
ET420DC-M420S	Collet – 1-1/4" 1-wire (20ZA series)

'Z' Series Collets

For use with:
T-410, T-440, ET4000 and ET4001.

Part Number	Description
T-440-85C	Collet – 5/8"
T-440-86C	Collet – 3/4"
ET4000DC-M380S	Collet – 1"
ET4000DC-M480S	Collet – 1-1/4" 2-wire (20Z series)
ET4000DC-M420S	Collet – 1-1/4" 1-wire (20ZA series)
ET4000DC-M530S	Collet – 1-1/2" H190 hose
ET4000DC-M560S	Collet – 1-1/2" H280 hose
ET4000DC-M550S	Collet – 2" H190 & H280 Hose
ET4000DC-M580S	Collet – 2" H290 hose

Coll-O-Crimp Spacer Rings

Spacer Rings

 Refer to pages A-2 and A-3 and machine operator's manuals for safety information.



Note:

See Crimp Bulletin # W-HOOV-TM001-E2 for proper Spacer Ring selection for hose style and size desired.

Note:

Spacer rings may ONLY be ordered individually, no sets available.

For use with T-400, T-460, T-462, T-465.

* T-400 machine only

Catalog Number	Color 5" Diameter	Catalog Number	Color 5" Diameter	Catalog Number	Color 5" Diameter
T-400-10	Black	T-400-45R*	Black/Yellow	ET1000SR-M100A	Purple
T-400-11	Silver	T-400-46R	Black/Tan	ET1000SR-M190D	Lt. Green
T-400-112	Tan	T-400-47R	Black/Red	ET1000SR-M215A	Magenta
T-400-37	Green	T-400-48R*	Black/Orange	ET400SR-001*	Black/Red
T-400-38	Red	T-400-49R	Black/Silver	ET400SR-002*	Black/Green
		T-400-62	Yellow	ET400SR-003*	Black/Purple

For use with T-420.

Catalog Number	Color 5" Diameter	Catalog Number	Color 5" Diameter	Catalog Number	Color 5" Diameter
T-400-10	Black	T-400-47R	Black/Red	ET1000SR-M100A	Purple
T-400-11	Silver	T-400-62	Yellow	ET1000SR-M190D	Lt. Green
T-400-112	Tan	T-420-29	Orange	ET1000SR-M215A	Magenta
T-400-37	Green	T-420-80R	Black/White	ET420SR-M255A	Blk/Grey
T-400-38	Red	T-420-81R	Black/Orange	ET420SR-M495A	Brown
T-400-46R	Black/Tan	T-420-82R	Black/Blue	ET420SR-M660A	Pink

For use with T-480.

Catalog Number	Color 5" Diameter	Catalog Number	Color 5" Diameter	Catalog Number	Color 5" Diameter
T-400-10	Black	T-400-62	Yellow	ET1000SR-M100A	Purple
T-400-11	Silver	T-420-29	Orange	ET1000SR-M190D	Lt. Green
T-400-112	Tan	T-420-80R	Black/White	ET1000SR-M215A	Magenta
T-400-37	Green	T-420-81R	Black/Orange	ET420SR-M255A	Blk/Grey
T-400-38	Red	T-420-82R	Black/Blue	ET420SR-M495A	Brown
T-400-46R	Black/Tan	T-480-68	Blue	ET420SR-M660A	Pink
T-400-47R	Black/Red	ET1000C-0012	Blue		

For use with T-410, T-440, ET4000.

Catalog Number	Color 5" Diameter	Catalog Number	Color 5" Diameter	Catalog Number	Color 5" Diameter
T-410-10	Black	T-410-93	Orange	ET4000SR-M180A	Blk/Purple
T-410-11	Silver	T-440-78R	Black/Tan	ET4000SR-M050A	Blk/Green
T-410-12	White	T-440-79R	Black/Red	ET4000SR-M560A	Pink
T-410-39	Green	T-440-80R	Black/White	ET4000SR-M100A	Purple
T-410-40	Red	T-440-81R	Black/Orange	ET4000SR-M405A	Brown
T-410-41	Yellow	T-440-82R	Black/Blue	ET4000SR-M345A	Blk/Brown
T-410-42	Tan	ET4000SR-M215A	Blk/Magenta	ET4000SR-M190D	Lt. Green

For use with ET1000.

Catalog Number	Color 5" Diameter	Catalog Number	Color 5" Diameter	Catalog Number	Color 5" Diameter
T-400-10	Black	T-400-62	Yellow	ET1000SR-M100A	Purple
T-400-11	Silver	T-420-80R	Black/White	ET1000SR-M190D	Lt. Green
T-400-37	Green	T-420-81R	Black/Orange	ET1000SR-M215A	Magenta
T-400-46R	Black/Tan	T-420-82R	Black/Blue	ET420SR-M255A	Blk/Grey
T-400-47R	Black/Red	ET1000C-0012	Blue	ET420SR-M495A	Brown
				ET420SR-M660A	Pink

Coll-O-Crimp Pumps

T-481-110 Electric Pump (110 volt)

For use with
T-480-EP,
ET10000.



Pump Specifications

Dimensions

14-14" High x 9-5/8" long x
9-5/8" wide

Weight

32 lbs.

Operation Pressure

0-10,000 psi

Hydraulic Oil

Use Enerpac Oil ONLY

T-482-2 Air/Hydraulic Pump

For use with
T-480-AH,
ET1000



Pump Specifications

Dimensions

5" High, 14-5/8" long, 5-5/8"
wide

Weight

12 lbs.

Operation Pressure:

0-10,000 psi

Hydraulic Oil

Use Enerpac Oil ONLY

T-433 Two-Stage Piston Pump (220v)

For use with T-407 Production
Press, T-400-1
or T-420-1.

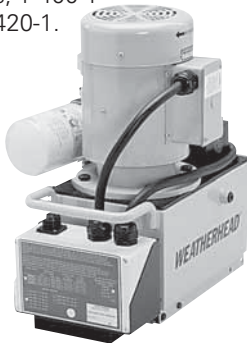

The Weatherhead T-433 two stage piston pump power unit is a high capacity pump especially suited for the T-407 Production crimper. It features a two stage piston pump providing high flow at low pressure for fast ram approach and low flow at high pressure for actual crimping. When used in conjunction with the T-433-2 connector cable, the T-433 can be used as an optional high capacity pump for the T-400-1 or T-420-1 Coll-O-Crimp presses.

Pump Specifications

Dimensions

22" high, 12" long, 15" long

Weight

127 lbs.

Operation Pressure

4,000 PSI

Reservoir Capacity

2 gallons

Outlet Port Size

3/8" Pipe Thread

Motor

1-1/2" H.P., 220 volts 60hz
single phase

Hydraulic Oil

Use Enerpac Oil ONLY

Flow

2.78 GPM @ 800 PSI, 0.52
GPM @ 4000 PSI

Replacement Parts

T-421-FP 220v 4 wire Female
electrical receptacle.

T-433-1 Foot Switch Assembly

T-402-2 Air/Hydraulic Pump

For use with T-400-1.

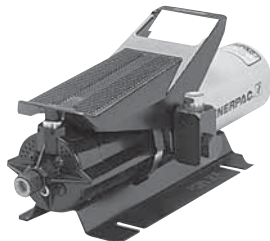

Pump Specifications:

Dimensions:

5-1/4" high, 12-1/2" long,
5" wide

Weight: 18 lbs.

Operation Pressure:

4000-4200 PSI

Reservoir Capacity: 1 pint

Hydraulic Oil

Use Enerpac Oil ONLY

Outlet Port Size

3/8" NPT

Inlet (Air) Port Size

1/4" NPT

Inlet Air Pressure Required

60 to 120 PSI

Note:

It is recommended that a filter, regulator, lubricator, and air pressure gauge be installed in the air line as close as possible to the pump. Filter, Regulator, and Lubricator units not included.

Some models have air port on right side.

T-403-2 Hand Pump

For use with T-400-1.



Pump Specifications:

Dimensions

7 high, 21" long, 4-3/4" wide

Weight

9 lbs.

Operation Pressure:

4000-4200 PSI

Reservoir Capacity

1 qt.

Outlet Port Size

3/8"

NPT Hydraulic Oil

Use Enerpac Oil ONLY

For repair and replacement items for the following pumps please contact an Enerpac Distributor at www.enerpac.com: T-402-2, T-403-2, T-481-110 & T-482-2.

Coll-O-Crimp Pumps

T-412 • Mobile Electric Pump

For use with T-400-1.



Pump Specifications:

Dimensions: 7-1/2" high, 14-1/2" long, 9" wide

Weight: 65 lbs.

Operation Pressure: 4000-4200 PSI

Reservoir Capacity: 3 quarts

Outlet Port Size: 3/4"-16 straight thread

Motor: 2 volt D.C.

Replacement Parts:

Catalog Number	Description
T-401-1B	Replacement Gasket between motor and square reservoir
T-401-1BC	Breather Cap for Fenner-Stone pumps

Hydraulic Oil: SAE 10W hydraulic oil or (ATF) Automatic Transmission Fluid

Flow: 0.5 GPM

T-421U Electric Pump (220 Volt)

For use with T-400-1 and T-420-1.

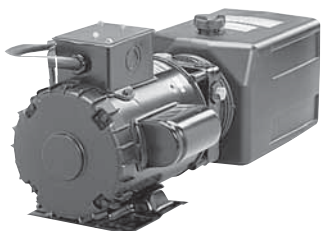

Pump Specifications:

Dimensions: 7-1/2" high, 22" long, 10" wide

Weight: 75 lbs.

Operation Pressure: 4000-4200 PSI

Reservoir Capacity: 6 quarts

Outlet Port Size: 3/4"-16 Straight Thread

Motor: 1 H.P., 3450 R.P.M., 220 volts, 60 cycle, single phase
At 50 Hertz, RPM = 2,850
At 60 Hertz, RPM = 3,450

Hydraulic Oil*: ISO 32 hydraulic oil or (ATF) automatic transmission fluid

*For low temperature applications automatic transmission fluid can be substituted.

Flow: 2.5 GPM @ 750 PSI, 0.5 GPM @ 4000 PSI

Note:

It is recommended that the electric pump be used on a 15 amp. fused circuit. Pump wired for 220 volts, single phase.

Replacement Parts:

Catalog Number	Description
140-06761	Relay for T-421U, T-441 and T-441 pumps only
T-421U-BC	Breather Cap - twist lock
T-421-FP	220v 4 wire Female electrical receptacle
T-401-1BC	Breather Cap → threaded

T-421U-110 Electric Pump (110 Volt)

For use with T-400-1 and T-420-1.

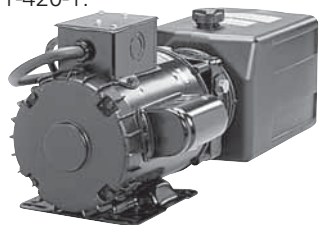

For dimensional data other than voltage information, refer to T-421U see above.

Note: It is recommended that the electric pump be used on an individual 30 amp. fused circuit.

Pump wired for 110 volts, single phase.

Assembly Equipment

T-441 Electric Pump (220 Volt)

For use with T-440-1 and ET4000 only.

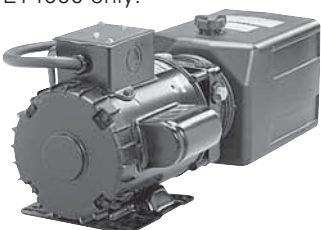

The Weatherhead T-441 power unit is designed for use with the latest Coll-O-Crimp II Plus press. It features a two-stage pump providing high flow at low pressure for fast ram approach and low flow at high pressure for actual crimping.

Pump Specifications:

Dimensions: 7-1/2" high, 22" long, 10" wide

Weight: 75 lbs.

Operation Pressure: 5,000 PSI

Reservoir Capacity: 6 quarts

Outlet Port Size: 3/4"-16 Straight Thread O-Ring

Motor: 1 H.P., 3450 R.P.M., 220 volts, 60 cycle, single phase

Hydraulic Oil: ISO 32 hydraulic oil automatic transmission fluid

Flow: 2.5 GPM @ 750 PSI, 0.5 GPM @ 5000 PSI

Replacement Parts:

T-421U-BC	Breather Cap
T-421-FP	220v 4 wire Female electrical receptacle.
140-06761	Relay for T-421U or T-421U-110 pumps

Note:

T441 pump is to be used with T440-1 and ET4000 press only. When replacing the pump on a standard T-410 Coll-O-Crimp II Press (without the black switchbox on the side of the press) refer to the repair and replacement items on page N-23.)

Coll-O-Crimp Pumps

T-460-2 Hand Pump

For use with T-450-1, T-460 and T-465



Pump Specifications

Dimensions
5-5/8" High, 13-1/4" long,
3-3/4" wide

Weight
4-1/2 lbs.

Operation Pressure
0-10,000 PSI

Reservoir Capacity
20 cu in.

Relief Valve Setting
10,000 PSI

Hydraulic Oil:
Use Enerpac Oil ONLY

Note:
For repair and replacement items for the following pumps please contact an Enerpac Distributor at www.enerpac.com:

T-402-2, T-403-2, T-433, T-460-2, T-462-2, T-480-2, T-480-3, T-481-110 & T-482-2.

T-462-2 Air/Hydraulic Pump

For use with T-462.

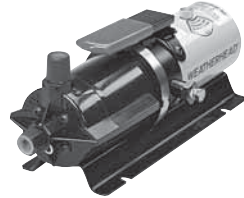

The Weatherhead T-462-2 power unit is a air/hydraulic pump designed for use with the T-462 portable system. Ideal if you have the availability of compressed air in your shop or in the field via a portable compressor.

Pump Specifications

Dimensions
4" high, 13" long

Weight
8 lbs.

Operation Pressure
0-10,000 PSI

Reservoir Capacity
10 cu in.

Relief Valve Setting
10,000 PSI

Hydraulic Oil
Use Enerpac Oil ONLY
Regulator to be set for 100-120 PSI inlet air.

Repair and Replacement Items for Discontinued T-401-1 Pump

Catalog Number	Description
T-401-1BC	Breather Cap for Fenner-Stone pumps
T-401-1S	Toggle Switch
T-401-SVF	Shuttle Valve for Fenner-Stone pump

T-480-2 Two-Stage Hand Pump

For use with T-480-HP, ET1000



Pump Specifications:

Dimensions
7-3/16" high x 21-1/64" long x 4-3/4" wide

Weight
9 lbs.

Operation Pressure
0-10,000 PSI

Hydraulic Oil
Use Enerpac Oil ONLY

T-480-3 Turbo Air/Hydraulic Pump

For use with T-480-TA.



Pump Specifications

Dimensions
8-1/4" High x 12-3/8" long x 8" wide

Weight
16-1/2 lbs.

Operation Pressure
0-10,000 PSI

Hydraulic Oil:
Use Enerpac Oil ONLY

For repair and replacement items for the following pumps please contact an Enerpac Distributor at www.enerpac.com:

T-402-2, T-403-2, T-460-2, T-462-2, T-480-2, T-480-3, T-481-110 & T-482-2.

T-421-FP 4-Prong Female Electrical Outlet

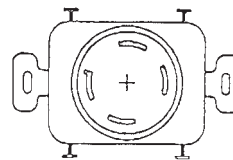

All Weatherhead 220v Coll-O-Crimp power pumps are equipped with a four prong electrical outlet as illustrated.



To obtain corresponding female wall receptacle order T-421-FP. For use with T-421U, T-441 & T-433 pumps.

Tooling - Competitor Conversion Kits

Conversion Tooling

 Refer to pages A-2 and A-3 and machine operator's manuals for safety information.

T-400-NP60 Dayco to Weatherhead Conversion Kit



The T-400-NP60 Conversion Kit is designed to allow the use of standard Weatherhead Coll-O-Crimp tooling, hose, and hose ends in the Dayco NP60, (2) tie rod, crimp machine. Everything is included to convert the crimper to accept Weatherhead tooling. This kit gives the crimper capacity to crimp up to and including 1-1/4" I.D. 4-spiral wire hose assemblies.

T-400-NP60 Kit Includes:

Part Description	Qty
Base Plate Assembly	1
Dayco Pusher Spacer	1
3/8-16 x 1.75 Cap Screw	1
Adapter Ring for T-400 Collets	1
Instruction Kit	1

T-400-DE60 Dayco to Weatherhead Conversion Kit



See pages N-26-32 for collets and spacer rings.

The T-400-DE60 Conversion Kit is designed to allow the use of standard Weatherhead Coll-O-Crimp tooling, hose and hose ends in the Dayco DE60, (4) tie rod, crimp machine. Everything is included to convert the crimper to accept Weatherhead tooling. This kit gives the crimper capacity to crimp up to and including 1-1/4" I.D. 4-spiral wire hose assemblies.

T-400-DE60 Kit Includes:

Part Description	Qty
Base Plate Assembly	1
Dayco Pusher Spacer	1
3/8-16 x 1.75 Cap Screw	1
Adapter Ring for T-400 Collets	1
Instruction Kit	1

T-400-GT Gates PC707 Conversion Kit



The T-400-GT Conversion Kit is designed to allow the use of standard Weatherhead Coll-O-Crimp tooling, hose, and hose ends in the Gates PC707 crimper. Everything is included to convert the crimper to accept Weatherhead tooling. This kit gives the crimper capacity to crimp up to and including 1-1/4" I.D. 2-wire hose factory-type hose assemblies.

This kit does not include the T-400-8 Die Ring which is required for crimping. If you do not already have the die ring or collets, you can order the kit to the right.

T-400-GT kit includes:

Pusher, 10-24 x 1/4 Set Screws (2), Spacer (2), Instructions

T-400-GTK • Gates PC707 Conversion Kit

Kit includes one each of the following:

Catalog Number	Description
T-400-GT	Conversion Kit
T-400-2C	'U' Series Collet - 1/4"
T-400-3C	'U' Series Collet - 3/8"
T-400-4C	'U' Series Collet - 1/2"
T-400-5C	'U' Series Collet - 3/4"
T-400-6C	'U' Series Collet - 1"
T-400-8	Die Ring - 3/16" thru 1-1/4"
T-400-10	Spacer Ring - Black
T-400-11	Spacer Ring - Silver

T-400-PH Parker 80c Conversion Kit



The T-400-PH Conversion Kit is designed to allow the use of standard Weatherhead Coll-O-Crimp tooling, hose, and hose ends in the Parker 80c crimper. Everything is included to convert the crimper to accept Weatherhead tooling. This kit gives the crimper capacity to crimp up to and including 1-1/4" I.D. 2-wire hose factory-type hose assemblies. If you do not already have the collets and spacer rings, you can order the kit to the right.

T-400-PH Kit includes:

1/4-20 x 1 Cap Screw (4), Dowel Pin Spacer (2), 1/4" Lockwasher (4), Spacer Bracket (4), Adapter Die Ring, Instructions

T-400-PHK • Parker 80c Conversion Kit

Kit includes one each of the following:

Catalog Number	Description
T-400-PH	Conversion Kit
T-400-2C	'U' Series Collet - 1/4"
T-400-3C	'U' Series Collet - 3/8"
T-400-4C	'U' Series Collet - 1/2"
T-400-5C	'U' Series Collet - 3/4"
T-400-6C	'U' Series Collet - 1"
T-400-10	Spacer Ring - Black
T-400-11	Spacer Ring - Silver

Tooling

Tube Flaring Tools

T-1290 • Segmented Flaring Tool (37°)

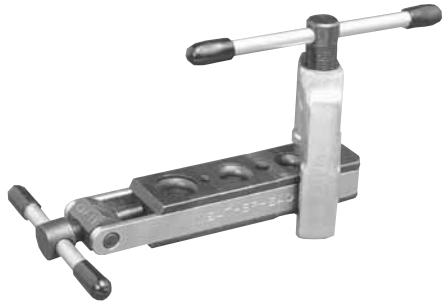

Hard chrome-finished cone makes exceptionally smooth flares and minimizes amount of effort needed. Forged steel yoke for maximum strength. Sliding die blocks lock in place by lever clamp action.

Flaring Capacity

3/16", 1/4", 5/16", 3/8", 1/2" and 5/8" O.D. Forms 37° SAE flares in soft copper, aluminum, brass, and Bundyweld tubing.

Weight

1 lb., 11 oz.

T-1295 • Heavy-Duty Segmented Flaring Tool (37°)

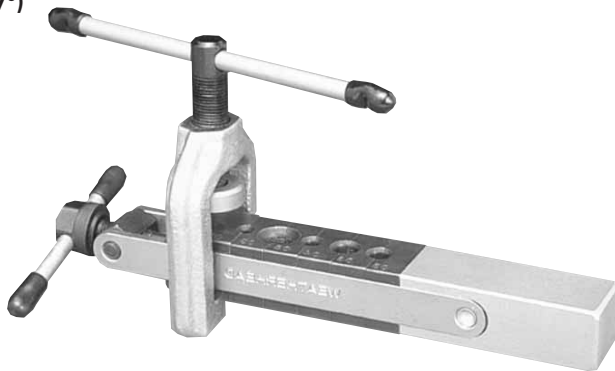

Ideal for use where considerable number of 37° flares in stainless steel tubing must be made. Built to withstand continuous rugged service. Ball thrust mechanism reduces effort required. Hardened tool steel die features non-slip grip of tubing – even after repetitive flaring. Bar has vise extension.

Flaring Capacity

1/8", 3/16", 1/4", 5/16", 3/8", and 1/2", O.D. tubing. Forms 37° SAE flares in annealed stainless steel (MIL-T-6845 or AMS-5566), cold drawn stainless steel, and annealed copper, brass, steel, or aluminum.

Weight

3 lbs.

Tooling

Hose Cutting Equipment

 Refer to safety information regarding Coll-O-Crimp hose, hose fittings and assembly equipment compatibility on pages A-2-3.

T-60A Portable Cutter



An excellent heavy-duty cutting machine. The T-60A is a portable power saw that can cut all hoses, including wire-reinforced. Includes three abrasive blades.

Replacement Blade T-1060A 14" diameter

Motor
3-1/2 H.P., 110/115 volts

Amps
15 amps

Weight
45 lbs.

RPM
3500

Note

Three blades are mounted on shaft for shipping purposes. Remove prior to use.

T-10B Hose Cutting Machine



The T-10B hose cutting machine assures quick, clean, right angle cuts, eliminating ragged and frayed cut ends which make hose assembly difficult and are a possible cause of premature hose failure. A powerful 1 H.P. motor and belt-driven blade cut all low, medium, and high pressure fabric and wire-braided hose from 3/16" through 1-1/4" I.D. 2 wire hose. Specifically designed for cutting hose, the T-10B is a natural companion to the T-400-1 Coll-O-Crimp and T-300 hose assembly machines.

Ordering Options

T-10B= saw with smooth edge blade for cutting up to 1-1/4" 1-wire hose

T-10B-1= saw with scalloped edge blade for cutting up to 1-1/4" 2-wire hose.

Replacement Blades

T-1047 (Smooth)

T-1047-1 (Scalloped)

Replacement Belt for T-10B & T-10C

T-10V-1 Belt

Motor

1 H.P., 3450 RPM, 115, 60 cycle, single phase

Size

13" wide, 24" long, 17" high

Weight

85 lbs.

Amps Drawn

115 volts – 15 amps

Replacement Parts

T-10-D Hose/Dowel

T-10-H Handle

T-10-P Pusher

Tooling

Hose Cutting Equipment

 Refer to safety information regarding Coll-O-Crimp hose, hose fittings and assembly equipment compatibility on pages A-2-3.

T-9-1 & T-9-3 Hose Cutting Machine



The T-9-1 and T-9-3 provide the capability for cutting multi-spiral and braided wire-reinforced hose through 2" I.D. Either machine is a perfect companion for the ET4000 press. Includes scalloped blade.

Note
The T-9-1 and T-9-3 are shipped less a line cord and plug. An electrician is recommended for direct electrical hook-up.

T-9-1

Motor
3 H.P., 230 volts, 60 cycle, single phase

Size
24" wide, 24" deep, 24" high

Weight
Approx. 255 lbs.

Amps Drawn
At 230 volts – 17

T-9-3

Motor
3 H.P., 230 volts, 60 cycle, 3 phase

Size and Weight
Same as T-9-1

Amps Drawn
At 230 volts – 8 amps

Replacement Blade:
T-75-14 Scalloped
T-75-17 Carborundum
T-75-11 Smooth

Guard
T-9-G

T-71 Hose Cutting Machine



This cutting machine easily handles all 1 and 2 braided wire hose through 4" I.D., up to 2" I.D. 4-spiral and up to 1-1/2" I.D. 6 multi-spiral reinforced hose. That makes this machine ideal for cutting most hydraulic and pneumatic hoses as well as a variety of industrial fluid transfer hoses. The T-71 uses a 14" cutting blade, T-1070, for cutting all 1 & 2 wire braid and through 2" 4 spiral hose. The scalloped toothed blade T-1071, is for cutting industrial transfer hoses through 4" and the smooth

beveled blade, T-1072, for cutting hose with a wire braid cover. T-71 includes a scalloped blade.

The T-71 is shipped with a scalloped blade, T-1070.

Replacement Blade

T-1070 Steel Scalloped

T-1071 Steel Scalloped Toothed

T-1072 Steel Smooth Beveled

Motor
4.5 H.P., 110/115 volts, single phase, 60 cycle

Size
22" wide, 19" deep, 25" high

Weight
Approx. 85 lbs.

Amps Drawn
115 volts – 20 amp

Hose Cutting and Skiving Wheels



Part Number	Type	Blade Dia.	Hole Dia.	Applicable Machinex
Cutting Wheels				
T-1042	Carborundum	8"	5/8"	T-10A
T-1047	Steel Smooth	7"	5/8"	T-10B & T-10C
T-1047-1	Steel Scalloped	7"	5/8"	T-10B & T-10C
T-1060	Carborundum	12"	1"	T-60
T-1060A	Carborundum	14"	1"	T-60A
T-1070	Steel Scalloped	14"	1"	T-70, T-71
T-1071	Steel Scalloped Toothed	14"	1"	T-70, T-71
T-1072	Steel Smooth Beveled	14"	1"	T-70, T-71
T-75-11	Steel Smooth	10"	3/4"	T-9/T-75
T-75-14	Steel Scalloped	10"	3/4"	T-9/T-75
T-75-17	Carborundum	10"	3/4"	T-9/T-75
Skiving Wheels				
T-75-12	Wire	8"	1"	T-75
Belts				
T-76-B	Reinforced	1"		Old T-76/T-76-1

Tooling

Hose Cutting Equipment

 Refer to safety information regarding Coll-O-Crimp hose, hose fittings and assembly equipment compatibility on pages A-2-3.

T-1037 Knife



An inexpensive, reliable knife useful in splitting twin-line and multiple-line hoses quickly and easily.

Replacement Blade T-1037B

Replacement Handle T-1037H

T-135 Plastic Tube and Hose Cutter



An economical alternative to quality tube and hose cutting. This versatile tool is lightweight and durable for long service life.

Replacement Blade T-135B

Capacity Up to 1" hose I.D.

Note
Not for use with wire-reinforced hose.

T-191 Plastic Tube and Hose Cutter



Only 2-7/8" long, the versatile T-191 offers quick and clean square cuts on 1/16" to 1/2" O.D. plastic tubing and non-wire reinforced hose. The T-191 can be either bench or wall mounted and offers the safety of closing automatically when not in use.

Spare Parts T-191B Replacement Blade (one per package)

T-570-1 Ermeto-Quick Set™ Preset Machine



The Ermeto-Quick Set Machine is ideal for bulk assemblies. It has a positive-stop action, which guarantees uniform repeatability, and a hand pump operation which yields quick cycle time, reducing assembly time. The T-570 is an easy tool to use that will save you time and money.

T-570 Package includes:

Part Number	Description
T-460-2	Hand Pump (10,000 PSI)
T-450-3	Quick Disconnect Hose Assembly
T-570-1	Ermeto Preset Machine
T-570-4	Preset Die
T-570-6	Preset Die
T-570-8	Preset Die
T-570-12	Preset Die
T-570-16	Preset Die
T-571-4	Tube Support
T-571-6	Tube Support
T-571-8	Tube Support
T-571-12	Tube Support
T-571-16	Tube Support

-10, -20, -24, and -32 sizes also available.

Ermeto Hand Presetting Tools 7000 Series



Presetting tools provide a more accurate and positive leak-proof method of coupling flareless fittings. Presetting steel Ermeto sleeves on tubing prior to fitting assembly will permit the maximum high performance obtainable with flareless fittings. Due to possible thread galling, the use of presetting tools is required when assembling stainless steel fittings.

Part Number	Tube O.D. (Inches)	Thread Size
T-7002	1/8	5/16-24
T-7003	3/16	3/8-24
T-7004	1/4	7/16-20
T-7005	5/16	1/2-20
T-7006	3/8	9/16-18
T-7008	1/2	3/4-16
T-7010	5/8	7/8-14
T-7012	3/4	1 1/16-12
T-7016	1	1 5/16-12
T-7020	1-1/4	1 5/8-12
T-7024	1-1/2	1 7/8-12
T-7032	2	2 1/2-12

Metric Flareless Hand Presetting Tools

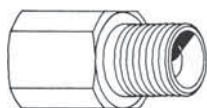

Presetting tools provide a more accurate and positive leak-proof method of coupling flareless fittings. Presetting the steel metric sleeves prior to fitting assembly will permit the maximum high performance obtainable with flareless fittings. These tools are available for both the Light (DIN 3901/3902L) flareless series.

Light Series 3901/3902L

Part Number	Tube O.D. (mm)	Thread Size
TL-7008	8	M14x1.5
TL-7010	10	M16x1.5
TL-7012	12	M18x1.5
TL-7015	15	M22x1.5
TL-7018	18	M26x1.5
TL-7022	22	M30x2.0
TL-7028	28	M36x2.0

Tooling

Hose Bore Cleaning Brushes

Individual Brushes



Hose I.D. (inch)	Part Number	Bristle O.D. (inch)	Bristle Length (inch)	Overall Length (inch)
3/16-3/8	T-1106	3/8	2	24
1/2-5/8	T-1110	1/2	3	24
3/4-1	T-1116	1	4	24
1-1/8-1-1/2	T-1124	1-1/2	4	24
2-3	T-1132	2	5	24

T-1100 3-Piece Kit



Hose I.D. (inch)	Part Number	Bristle O.D. (inch)	Bristle Length (inch)	Overall Length (inch)
3/16-3/8	T-1106	3/8	2	24
1/2-5/8	T-1110	1/2	3	24
3/4-1	T-1116	1	4	24

Tooling

Skiving Tools and Wrenches

Hand Skiving Tool

(For H470 Hose)



Order hand skiving tool components by the individual catalog numbers listed.

See page A-30 for skiving instructions.

T-410-36

Handle

T-410-37

Replacement cutting blades

Hose Size	Skiving Tool Cutting Head H470
1/2" I.D.	T-410-50
3/4" I.D.	T-410-52
1" I.D.	T-410-53
1-1/4" I.D.	T-410-54
1-1/2" I.D.	T-410-55
2" I.D.	T-410-56

Rapid Wrenches



The Rapid Wrench is a heavy-duty, high quality wrench that ratchets for quick installation and removal of tube fittings and hose ends. These wrenches have jaws that snap open and close completely around the fitting giving 6-point contact. Needing only 30° of rotation to ratchet, they allow easy access to tight locations. Available individually or in a set with pouch, these wrenches are a welcome addition to any tool box.

T-152

11-Piece Set with Pouch

T-152P

Pouch for 11-Piece Set

Catalog Number	Wrench Hex Size
T-140	3/8"
T-141	7/16"
T-143	9/16"
T-144	5/8"
T-145	11/16"
T-146	3/4"
T-147	13/16"
T-148	7/8"
T-151	15/16"
T-149	1"

Tooling

Power Steering Make-Up Information

H32406 Passenger Car Power Steering Hose



The Coll-O-Crimp System may be used to supplement the original equipment-type power steering hose assembly inventory by using hose ends listed below and tubing (from the old hose assembly) to duplicate out-of-stock or slow-moving hose assemblies.

Reinforcement
2 Fiber Braids

Cubical Expansion
8 to 17 cc ft. @ 1300 psi

Operating Temperature
-40°F to +250°F

SAE J188 Type 2

Hose I.D.	Hose O.D.	Catalog Number	Recom. Oper. Press.	Min. Burst Press.	Bend Radii
3/8	13/16	H32406	1500	6000	3-1/8

All dimensions in inches; pressure in psi

On many of late model cars the formed tubing from the old line with its complicated bends can be utilized to make up a new assembly. Just use a tube cutter to cut the old tube as close to the hose as possible, then make up a hose assembly with a flareless tube end (i.e., 06U-756) and attach to the old tubing. Reference flareless tube assembly instructions on page L-78.

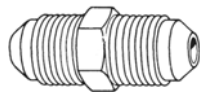
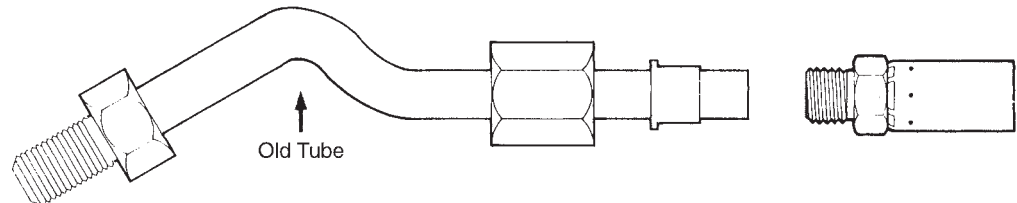

42x6
SAE 45° flare union

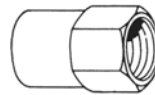

252x6, 252x7
Inverted flare to female pipe



1439, 1440, 41157x6
O-ring port to JIC 37° flare
M41157x6x14, M41157x6x16, M41157x6x18
Metric o-ring port to JIC 37° flare

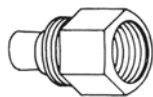

1444, 1445, 1446, 1447
O-ring port to female inverted flare

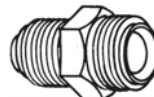

1553, 1554, 1563
Inverted flare to SAE 45° flare

Tooling

Power Steering Make-Up Information

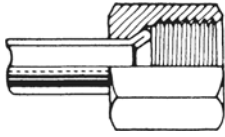

Original End

1/4" SAE Swivel 7/16-20

Configuration	Use Part Number
Straight	06U-604
45° Elbow	06U-684
90° Elbow (Short)	06U-664
90° Elbow (Long)	06U-644
Reuse old tube	06U-754

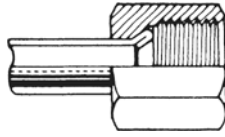

Original End

5/16" SAE Swivel 1/2-20

Configuration	Use Part Number
Reuse old tube	06U-755

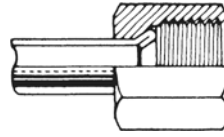

Original End

3/8" SAE Swivel 5/8-18

Configuration	Use Part Number
Straight	06U-406
45° Elbow	06U-486
90° Elbow	06U-446
Reuse old tube	06U-756

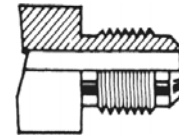

Original End

3/8" SAE 45° Rigid 5/8-18

Configuration	Use Part Number
Straight	06U-406 with 42x6
45° Elbow	06U-486 with 42x6
90° Elbow	06U-446 with 42x6
Reuse old tube	06U-756

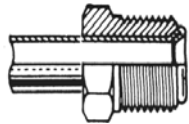

Original End

1/4" Inv. Swivel 7/16-24

Configuration	Use Part Number
Straight	06U-B04
45° Elbow	06U-B44
90° Elbow	06U-B64
Reuse old tube	06U-754

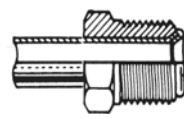

Original End

5/16" Inv. Swivel 1/2-20

Configuration	Use Part Number
Straight	06U-B05 or 06U-406 with 1553
45° Elbow	06U-B45 or 06U-486 with 1553
90° Elbow	06U-B65 or 06U-446 with 1553
Reuse old tube	06U-755

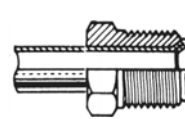

Original End

3/8" Inv. Swivel 5/8-18

Configuration	Use Part Number
Straight	06U-B06 or 06U-406 with 1563
45° Elbow	06U-B46 or 06U-486 with 1563
90° Elbow	06U-B66 or 06U-446 with 1563
Reuse old tube	06U-756

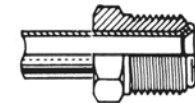

Original End

1/4" Inv. Swivel 7/16-24

Configuration	Use Part Number
Straight	06U-B04
45° Elbow	06U-B44
90° Elbow	06U-B64
Reuse old tube	06U-754

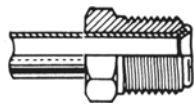

Original End

7/16" Inv. Swivel with 3/8" Tube Opening 11/16-18

Configuration	Use Part Number
Straight	06U-B07 or 06U-406 with 1554
45° Elbow	06U-B47 or 06U-486 with 1554
90° Elbow	06U-B67 or 06U-446 with 1554
Reuse old tube	06U-756
New tubing/nut	105x6x7

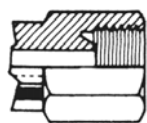

Original End

3/8" Inv. Seat 5/8-18

Configuration	Use Part Number
Straight	06U-104 with 252x6

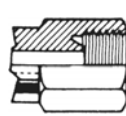

Original End

7/16" Inv. Seat 11/16-18

Configuration	Use Part Number
Straight	06U-104 with 252x6

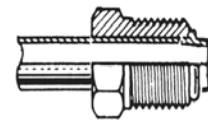

Original End

O-Ring Tube End 3/8" Tube – 5/8-18

Configuration	Use Part Number
Straight	06U-606 with 41157x6
45° Elbow	06U-686 with 41157x6
90° Elbow	06U-666 with 41157x6
Reuse old tube	06U-756

Tooling

Power Steering Make-Up Information

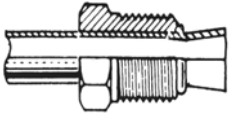

Original End

O-Ring Tube End (Chrysler)
5/16" Swivel 1/2-20

Configuration	Use Part Number
Reuse old tube	06U-755

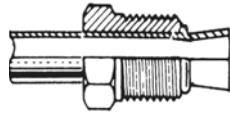

Original End

O-Ring Tube End (Ford) 1/4"
Tube -9/16-18 (Special)

Configuration	Use Part Number
Straight	06U-604 with 1440
45° Elbow	06U-684 with 1440
90° Elbow	06U-664 with 1440
Reuse old tube	06U-755

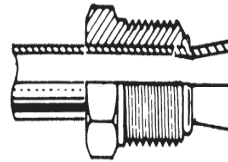

Original End

O-Ring Tube End 3/8"
Tube - 5/8-18 (Special)

Configuration	Use Part Number
Straight	06U-606 with 1439
45° Elbow	06U-686 with 1439
90° Elbow	06U-666 with 1439
Reuse old tube	06U-756

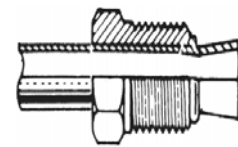

Original End

O-Ring Tube End (Ford) 7/16"
Tube -11/16-18 (Special)

Configuration	Use Part Number
Straight	06U-B06 with 1444
45° Elbow	06U-B46 with 1444
90° Elbow	06U-B66 with 1444
Reuse old tube	06U-756

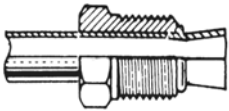

Original End

O-Ring Tube End 3/8"
Tube - M14x1.5

Configuration	Use Part Number
Straight	06U-B06 with 1445
45° Elbow	06U-B46 with 1445
90° Elbow	06U-B66 with 1445
Reuse old tube	06U-756

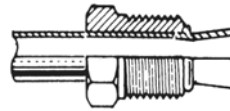

Original End

O-Ring Tube End 3/8"
Tube - M16x1.5

Configuration	Use Part Number
Straight	06U-B06 with 1446
45° Elbow	06U-B46 with 1446
90° Elbow	06U-B66 with 1446
Reuse old tube	06U-756

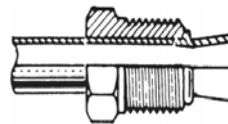

Original End

O-Ring Tube End 3/8"
Tube - M18x1.5

Configuration	Use Part Number
Straight	06U-B06 with 1447
45° Elbow	06U-B46 with 1447
90° Elbow	06U-B66 with 1447
Reuse old tube	06U-756

Tooling

Cable Controls

Vernier Controls

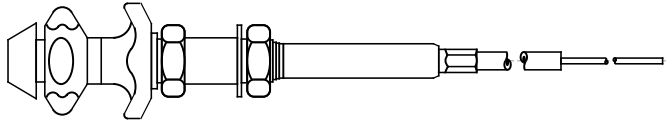

Catalog Number: 8374

Advanced styling. Meets or exceeds OEM specifications. Non-Corrosive aircraft aluminum body and stainless steel shaft assures 400-hour salt spray test without corrosion

A direct replacement for most "Remote Throttle

Controls"; Mack Truck 21QB-180 Series, Kenworth K068B Series, Peterbilt 05-1462 Series, Volvo-White 13401 Series, I.H. 34084 Series, Muncie COCL Series, BPC VCG Series. Also replaces most garage and service station wreckers remote control throttles; Earnest Holmes, Dover, etc.

Turn-To-Lock Controls (T-Locking)

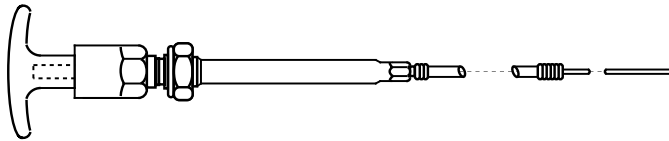

Catalog Numbers: 8370, 8371

Positive action control for small to mid-size engine throttles, governors, chokes, fuel shut-offs and more.

Aluminum body assures rust free performance. Acetal Locking bushing guarantees never before possible settings with one-third operator effort. Replaces Muncie COCL Series, and BPC R09 Series.

Power Take Off Controls (Ball Knob)

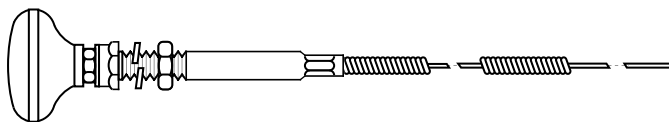

Catalog Numbers: 8372, 8373

Utility grade as exact replacement for most P.T.O. Controls.

Features 2" round knobs, galvanized steel, vinyl-covered casing and steel inner wire. All P.T.O. Controls meet or exceed OEM specifications. Replaces BPC R-38DS, R04, R38 and R38D Series, Muncie COKB Series.

Utility Light Load Controls (Dash)

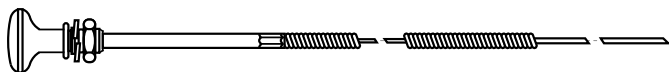

Catalog Numbers: 8375, 8376, 8377, 8378

Universal light load choke, fuel-shutoff, throttle, hood, Trunk and more! Controls are designed for most engine applications. Stainless steel inner-wire resists corrosion and assures trouble-free operation. Vinyl coated.

Throttle Stop



Catalog Number	Description
1548	.081" dia. hole (#46)

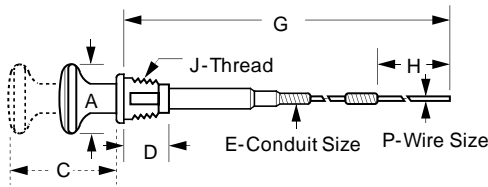

Specification Chart On Weatherhead "Push-Pull" Controls

Description	Dash				T-Hood	T-Locking	PTO Control		Vernier	Deluxe PTO Control		
Catalog Number	8375	8376	8377	8378	8367	8370	8371	8372	8373	8374	106370	106470
Length of "G"	84"	84"	84"	60"	180"	126"	186"	81"	165"	120"	192"	300"
Length of Wire "H"	9-3/8"	9-3/8"	9-3/8"	7"	5"	6"	6"	3"	3"	4-1/2"	12"	12"
Knob Type	Round				T-Handle	T-Handle	Round		Round	Round		
Knob Size "A"	1.06"				2"		2"		2"	2"		2"
Knob Color	Black				Chrome	Chrome	Black		Black	Red		
Knob Material	Plastic				Cast Zinc	Nylon	Plastic		Plastic	Plastic		
Knob Lettering	Choke	Throttle	None	None	None	Lock	None		None	None		
Knob Travel "C"	2-1/2"				2-1/2"	3"	3-1/2"		3-3/8"	4-1/2"		
Thread Size "J"	3/8"-24				3/8"-24	7/16"-20	7/16"-20	3/4"-16	1/2"-20			
Thread Length "D"	1/2"				1/2"	3/4"	1-5/32"		2-1/2"	1-1/8"		
Conduit Size "E"	3/16"				3/16"	3/16"	1/4"		1/4"	3/8"		
Conduit Material & Style	Galvanized Steel				Steel	Galvanized Steel	Galvanized Steel		Galvanized Steel	High Carbon		
	Vinyl	Vinyl	Vinyl	Vinyl	Cover	Vinyl Covered	Vinyl Covered		Vinyl Covered	Polyethylene Lining & Cover		
Wire Size "P"	.054"				.054"	.054"	.088"		.0625"	.088"		

Assortments

AB-8 & AB-9 Air Brake Air Chamber Hose



Assembly Assortment of 3/8" and 1/2" I.D. Lines

Each selection of fourteen ready-made air chamber hose assemblies facilitate replacement of hoses. Eliminates time and cost of making special assemblies. Wall rack keeps assemblies handy and ready to use.

AB-8 • 1/2" I.D. Air Brake Air Chamber Lines

Length	Quantity	Part Number
18-1/2"	1	38353-01800
20-3/8"	2	38353-02037
24-1/8"	2	38353-02400
28-3/8"	2	38353-02837
30-1/8"	2	38353-03000
32"	1	38353-03200
34-3/8"	1	38353-03437
36-1/8"	2	38353-03600
41-1/8"	1	38353-04112
	1	AB-8X (rack only)

Replacement Labels: AB-8L

AB-9 • 3/8" I.D. Lines Air Brake Air Chamber Lines

Length	Quantity	Part Number
18-1/2"	1	38166-01812
20-3/8"	2	38166-02137
24-1/8"	2	38166-02412
28-3/8"	2	38166-02837
30-1/8"	2	38166-03012
32"	1	38166-03200
34-3/8"	1	38166-03437
36-1/8"	2	38166-03612
41-1/8"	1	38166-04112
	1	AB-9X (rack only)

Replacement Labels: AB-9L

CA-130 & CA-230 Clamp Assortments



You can now increase your all-stainless steel or part-stainless steel clamp sales with these all-purpose clamp assortments. These rugged assortments can be wall mounted or stand free using less than 2 sq. ft. of counter space. They load easily and organize your merchandise effectively.

CA-130 Part-Stainless Steel

Part Number	Quantity
6205-004	20
6205-006	10
6203-010	20
6203-016	20
6203-020	20
6203-024	10
6203-036	10
CA-10X (rack only)	1

CA-230 All-Stainless Steel

Part Number	Quantity
6206-004	20
6206-006	10
6204-010	20
6204-016	20
6204-020	20
6204-024	10
6204-036	10
CA-10X (rack only)	1

RG-24 Hydraulic O-Ring Assortment

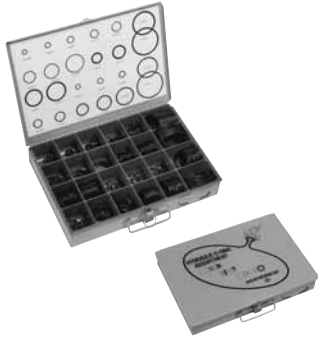

The Weatherhead RG-24 assortment is your solution to storing a useful inventory of hydraulic o-rings. This kit contains o-rings for Weatherhead straight thread and FOR-SEAL® tube fitting applications as well as popular split flange hydraulic applications. The RG-24 comes enclosed in a handy

steel case with a carrying handle. Consider an RG-24 for an over-the-counter sales merchandiser or keep one in your equipment shop or maintenance trailer to prepare for those critical “got-to-have-it” applications.

Twenty-four individual compartments keep your

hydraulic o-ring inventory separated by part number, and labeled illustrations on the inside of the assortment prevent the mix-up of o-rings. Compact, organized, and reasonably priced, if you specialize in hydraulic applications that call for o-rings — we’ve got your number — RG-24.

RG-24 • O-Ring Assortment Contents

Part Number	Split Flange Quantity	Part Number	FOR-SEAL Quantity	Part Number	Straight Thread Quantity
8x252	12	4629x4	12	7629x4	12
12x252	12	4629x6	12	7629x5	12
16x252	12	4629x8	12	7629x6	12
20x252	12	4629x10	12	7629x8	12
24x252	12	4629x12	12	7629x10	12
32x252	12	4629x16	12	7629x12	12
		4629x20	12	7629x16	12
		4629x24	12	7629x20	12
				7629x24	12
				7629x32	12

FL-310 Fuel Hose and Fittings Assortment



FL-310 contains 250' of Weatherhead fuel line hose, a variety of brass hose end fittings, and gear-type clamps for easy, instant service on fuel and oil line assemblies.

A well-designed cabinet keeps 1/4", 5/16", or 3/8" I.D. hose on reels free of kinks and tangles ready for instant

use. Ten clear plastic drawers with color-coded illustrated labels are provided for storing hose end fittings and clamps. H057 hose is compatible with unleaded gasolines and low pressure fuel systems.

Size

30" wide, 13-1/2" high, 13" deep

Part Number	Quantity	Part Number	Quantity
05704B-102	10	05706B-104	10
05704B-104	5	05706B-106	5
05704B-C02	5	05706B-1568	5
05705B-102	10	05706B-1570	5
05705B-104	10	05706B-C02	5
05705B-1560	5	05706B-C04	5
05705B-1561	5	6205-004	20
05705B-C02	5	CL-434	1
05705B-C04	5	FL-310X	1
05706B-102	10	H05704	100'
		H05705	100'
		H05706	50'

Assortments

SR3100W Weatherhead Air Conditioning Assortment



Air conditioning assortment kit; containing the most popular steel air conditioning hose ends for use with H757 air conditioning hose.

Included in Kit (various sizes)

- Bumped tube o-ring male swivels
- Bumped tube o-ring male swivel 90° tube elbows
- Bumped tube o-ring female swivels
- Bumped tube o-ring female swivel 90° tube elbows
- O-Ring Assortment
- Stackable sturdy steel case (18" x 12" x 3")

Part Number	Qty.	Part Number	Qty.	Part Number	Qty.	Part Number	Qty.
75706E-Z47	4	75706E-Z87	4	75708E-Z08	4	ZW74706	4
75708E-Z49	4	75708E-Z89	4	75710E-Z10	4	ZW74708	4
75710E-Z51	4	75710E-Z91	4	75712E-Z12	4	ZW74710	4
75712E-Z51	4	75712E-Z91	4	75706E-Z66	4	ZW74712	4
75712E-Z53	4	75712E-Z93	4	75708E-Z68	4		
		75706E-Z06	4	75710E-Z70	4		

FF12139 E-Z Clip System™



The E-Z Clip System is designed for assembly with weatherhead multi-Refrigerant hose GH134. It's engineered connection exceeds SAE J2064 and has been vibration and impulse tested.

Kit Contents Components

Part Number	Description	Qty/Per Kit
1F40104-size	Clips	20 each size
1F40105-size	Cages	10 each size
FT1357	Assy. Tool	1
T-135	Hose Cutter	1
T-135B	Replacement Blade	1

Note:

The E-Z Clip System has been designed to work exclusively with Weatherhead GH134W Hose.

BL-456 Barb-Tite Fittings and Hose Assortment



Making up an air line oil line transmission, or power steering return line? The BL-456 assortment puts Eaton Barb-Tite fittings and 1/4", 5/16", and 3/8" I.D. 350 psi maximum operating pressure H101 hose at your fingertips for quick and easy assembly. Simply push ends on hose, and you have a

hose assembly. No clamps required!

Measure the hose on top of the cabinet with the rule provided and then select the proper hose ends from the assortment in the two metal drawers. Within minutes the hose assembly is ready for installation.

Size

15" wide
16-1/2" high
13-3/16" deep
16 compartments in each drawer

Part Number	Qty.	Part Number	Qty.	Part Number	Qty.	Part Number	Qty.
10004B-102	4	10004B-B04	4	10005B-C02	4	10006B-606	4
10004B-104	4	10004B-B05	4	10005B-C04	4	10006B-B06	4
10004B-304	4	10004B-Y04	4	10005B-Y05	4	10006B-Y06	4
10004B-305	4	10005B-102	4	10006B-102	4	H10104	25'
10004B-605	4	10005B-104	4	10006B-104	4	H10105	25'
10004B-604	4	10005B-605	4	10006B-106	4	H10106	25'
10004B-A04	4	10005B-B05	4	10006B-306	4	FS-500	1
10004B-A05	4	10005B-B06	4	10006B-406	4	BL-456X	1
10004B-B03	4						

Assortments

Fleet Hose and Fitting Assortment



These assortments are ideal for servicing fleet accounts. The DOT-approved hose and fittings will enable the user to make up chamber

lines, connect to gladhand couplings, and provide routing for air brake lines. The general purpose H069 provides for fuel, oil,

water, power steering, and transmission lines. A self-contained assortment in a super cabinet, all set up for easy serviceability!

FA-100 • Fleet Hose and Fitting Assortment (with Cabinet) FA-100-CO • Fleet Hose and Fitting Assortment (Contents Only)

Part Number	Quantity	Part Number	Quantity	Part Number	Quantity
H06904	50'	24706N-106	5	33806-A	20
H06906	50'	24706N-406	5	33806-B	5
H06908	50'	24706N-604	5	33806B-Y06	5
H06910	50'	24706N-605	5	33806B-Y24	5
H16606	50'	24706N-606	5	33806B-Y26	2
H16608	50'	24706N-608	5	33806B-Y28	5
H33806	50'	24706N-756	5	33806B-Y34	5
24704N-102	5	24706N-B06	5	33806B-Y36	5
24704N-104	5	24708N-106	5	33806B-Y38	5
24704N-604	5	24708N-108	5	FH-15X	1
24704N-B04	5	24708N-406	5	HD-1X	1
24705N-104	5	24708N-608	5		
24705N-605	5	24710N-108	5		
24705N-B05	5	24710N-608	5		
24706N-104	5	24710N-610	2		

HA-574 Fuel Hose Merchandiser

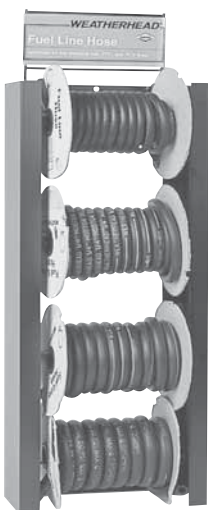

Now you can make those custom hose assemblies in minutes for instant service on fuel and oil line replacements. The attractive HA-574 includes H057 hose in all popular sizes for low

pressure fuel, EEC and PCV lines. Weatherhead H057 low pressure fuel line hose has Nitrile inner tube, fiber braid reinforcement, and Hypalon cover for long life compatibility with gasohol,

leaded, and unleaded fuels. The HC-574X rack can be easily installed on pegboard, wall, or metal shelving with the included hardware.

Part Number	Quantity	Description
H05703	25'	Hose
H05704	25'	Hose
H05705	25'	Hose
H05706	25'	Hose
HC-574X	1	Rack + 4 Dowels

Assortments

MA-100 • Metric Adapter Assortment

(with Cabinet)



The MA-100 is an ideal assortment to begin a metric adapter inventory. Offered are a variety of male British Standard Tapered Pipe (BSTP) and British Standard Parallel (BSPP) fittings in straight and 90° elbow configurations, sizes ranging from 1/8" through 1-1/4". Two male DIN (German metric) fittings adapt SAE fittings

and hose ends to metric size tubing, and a third DIN fitting connects SAE fittings with metric female swivel adapters, sizes ranging from 6mm through 42mm. The C5165X metric sleeves adapt metric tubing used with standard JIC fittings. The MA-100 is supplied with cabinet for accurate and easy access to your metric fittings.

Replacement Drawers PD-49 (one drawer)

Replacement Dividers PD-75 Set

MA-100 Contents

Part Number	Qty.	Part Number	Qty.	Part Number	Qty.	Part Number	Qty.	Part Number	Qty.
7165X6MM	5	M9600X8X8	2	MB5315X20X20	2	MC5315X4X12	2	ML7105X15	5
7165X8MM	2	M9600X10X8	2	MB5515X4X4	5	MC5315X6X14	2	ML7105X18	5
7165X10MM	5	M9600X12X12	2	MB5515X6X4	5	MC5315X6X16	2	ML7105X22	5
7165X12MM	5	M9600X16X16	2	MB5515X6X6	5	MC5315X8X8	5	ML7105X28	5
7165X14MM	5	M9600X20X20	1	MB5515X8X6	5	MC5405X4X4	5		
7165X15MM	5	M9700X4X6	2	MB5515X8X8	5	MC5405X5X4	5		
7165X16MM	5	M9700X5X8	2	MB5515X10X12	5	MC5405X6X4	5		
7165X18MM	5	M9700X6X10	2	MB5515X12X12	5	MC5405X6X6	5		
7165X20MM	5	M9700X8X12	2	MB5515X16X16	2	MC5405X8X6	5		
7165X22MM	5	M9700X10X14	2	MB5515X20X20	2	MC5405X8X8	5		
7165X25MM	5	M9700X12X20	2	MC5205X10X8	5	MC5405X10X12	5		
7165X28MM	5	M9700X16X25	2	MC5205X12X12	5	MC5405X12X12	5		
7165X30MM	5	M9700X20X32	1	MC5205X8X8	5	MC5405X16X16	2		
C5165X4X6MM	5	M9800X4X4	2	MC5206X4X6	2	MC5405X20X20	2		
C5165X5X8MM	5	M9800X5X4	2	MC5206X6X8	2	MC5515X10X20	2		
C5165X6X10MM	5	M9800X6X4	2	MC5206X8X10	2	MC5515X12X22	2		
C5165X8X12MM	5	M9800X8X4	2	MC5206X8X12	2	MC5515X12X27	2		
C5165X10X14MM	5	M9800X8X6	2	MC5206X10X15	2	MC5515X16X33	1		
C5165X10X15MM	5	M9800X8X8	2	MC5206X12X18	2	MC5515X4X12	2		
C5165X10X16MM	5	M9800X10X8	2	MC5207X4X6	2	MC5515X6X14	2		
C5165X12X18MM	5	M9800X12X12	2	MC5207X6X10	2	MC5515X6X16	2		
C5165X14X20MM	5	M9800X12X8	2	MC5207X6X8	2	MC5515X8X18	2		
C5165X16X25MM	5	M9800X16X12	2	MC5207X8X12	2	MH7105X6	5		
C5165X20X30MM	5	M9800X16X16	2	MC5207X10X15	2	MH7105X8	5		
C5165X20X32MM	5	M9800X20X20	1	MC5207X12X18	2	MH7105X10	5		
C-5X	1	MB5315X4X2	5	MC5208X10X14	2	MH7105X12	5		
C-63X	1	MB5315X4X4	5	MC5208X12X16	2	MH7105X14	5		
CL-502	1	MB5315X5X4	5	MC5208X6X6	2	MH7105X16	5		
FT1341	1	MB5315X6X4	5	MC5208X8X10	2	MH7105X20	5		
M5515X5X4	5	MB5315X6X6	5	MC5315X10X20	2	MH7105X25	5		
M9600X4X4	2	MB5315X8X18	2	MC5315X12X22	2	MH7105X30	5		
M9600X5X4	2	MB5315X8X6	5	MC5315X12X27	2	ML7105X6	5		
M9600X6X4	2	MB5315X10X12	5	MC5315X16X33	2	ML7105X8	5		
M9600X6X6	2	MB5315X12X12	5	MC5315X20X42	1	ML7105X10	5		
M9600X8X6	2	MB5315X16X16	2	MC5315X4X10	2	ML7105X12	5		

MA-200 • Metric Hose End Assortment

(with Cabinet)



The MA-200 hose end assortment offers an excellent introductory stock of metric hose ends. Coverage includes 'U' Series British Standard Tapered Pipe (BSPT) and British Standard Parallel Pipe (BSPP) in male straight, and female swivel in

straight and 90° tube elbow connections, swivels, and split flange ends for Komatsu and Link Belt applications and DIN standpipe hose ends in light and heavy series. One FH-15X stock cabinet is supplied for storage.

MA-200 Contents

Part Number	Qty.	Part Number	Qty.	Part Number	Qty.	Part Number	Qty.	Part Number	Qty.
04U-14K	2	06U-76P	2	12U-162	2	16U-P66	2	MH7105X14	2
04U-154	5	08U-158	5	12U-30K	2	7165X8MM	5	MH7105X16	2
04U-354	5	08U-22K	2	12U-362	2	7165X10MM	4	MH7105X20	2
04U-38T	2	08U-358	5	12U-52T	2	7165X12MM	2	MH7105X25	2
04U-40T	2	08U-360	5	12U-55T	2	7165X14MM	2	MH7105X30	1
04U-P54	5	08U-45T	2	12U-G12	2	7165X15MM	2	ML7105X8	2
04U-74P	2	08U-46T	2	12U-G42	2	7165X16MM	2	ML7105X10	2
06U-156	5	08U-P56	2	12U-P62	2	7165X18MM	2	ML7105X12	2
06U-18K	2	08U-P58	2	12U-82P	2	7165X20MM	2	ML7105X15	2
06U-356	5	08U-78P	2	16U-166	2	7165X22MM	2	ML7105X18	2
06U-358	2	08U-80P	5	16U-33K	2	7165X25MM	2	ML7105X22	2
06U-40T	2	10U-24K	2	16U-366	2	7165X28MM	2	ML7105X28	2
06U-42T	2	10U-48T	2	16U-58T	2	7165X30MM	1	FH-15X	2
06U-44T	2	10U-50T	2	16U-60T	1	MH7105X8	2	FS-2500	1
06U-P56	2	10U-G09	2	16U-G16	2	MH7105X10	2		
06U-P58	2	10U-G69	2	16U-G46	2	MH7105X12	2		

FA-15 Portable Coll-O-Crimp Assortment

(with Cabinet)



This portable assortment includes everything you need to service your hydraulic hose needs on the job site. Three sizes of 2 wire hose plus a variety of hose ends and adapters and a crimping system that requires no electrical power source makes this assortment the ultimate for field repairs. A 15-drawer cabinet is included for storage. Also available are

assortments with a cut-off saw or less the equipment.

FA-15

Includes contents listed below.

FA-15-CO

Includes contents listed below less equipment and cabinet.

FA-15-NH

Includes contents listed below less hose.

FA-15 Contents

Part Number	Qty.	Part Number	Qty.	Part Number	Qty.	Part Number	Qty.	Part Number	Qty.
04U-102	5	06U-406	5	06U-J06	5	08U-612	5	9405X8X8	5
04U-104	10	06U-506	5	06U-J08	5	08U-668	5	FH-15X	1
04U-106	5	06U-508	5	06U-P08	5	08U-J08	5	H42504	50'
04U-604	10	06U-606	10	08U-106	5	08U-P08	5	H42506	50'
04U-605	5	06U-608	5	08U-108	10	08U-P10	5	H42508	50'
04U-606	5	06U-666	5	08U-112	5	9205X2X2	5	T-465-HPU	1
04U-B04	5	06U-668	5	08U-508	5	9205X4X4	5	FS-1100	1
04U-J04	5	06U-755	5	08U-510	5	9205X6X6	5	FS-100	1
06U-104	10	06U-756	5	08U-512	5	9205X8X8	5		
06U-106	10	06U-B06	5	08U-608	10	9405X4X4	5		
06U-108	5	06U-B66	5	08U-610	5	9405X6X6	5		

Assortments

FA-135 Coll-O-Crimp I Assortment

(with Cabinet)



This assortment includes everything you need to start servicing hydraulic hose applications in your own shop. Five sizes of 2 wire hose along with a variety of hose ends and adapters gives you the versatility you need. In addition there is hose for power steering applications and a cabinet for storage. Also available are assortments with a cut-off saw or less the equipment.

FA-135

Includes contents listed below.

FA-135-CO

Includes contents listed below less equipment and cabinet.

FA-135-NH

Includes contents listed below less hose.

FA-135-10B

Includes contents listed below plus T-10B Saw.

FA-135 Contents

Part Number	Qty.	Part Number	Qty.	Part Number	Qty.
04U-102	5	06U-J08	5	12U-P12	5
04U-104	10	06U-P06	5	16U-116	5
04U-106	5	06U-P08	5	16U-516	2
04U-504	5	08U-058	5	16U-616	5
04U-505	5	08U-106	5	16U-676	1
04U-506	5	08U-108	10	16U-J16	1
04U-604	10	08U-112	5	41157X6	5
04U-605	5	08U-208	2	9205X2X2	5
04U-606	5	08U-508	5	9205X4X4	5
04U-664	5	08U-510	5	9205X6X6	5
04U-B04	5	08U-512	5	9205X6X8	5
04U-J04	5	08U-608	10	9205X8X6	5
06U-104	10	08U-610	5	9205X8X8	5
06U-106	10	08U-612	5	9405X4X4	5
06U-108	5	08U-668	5	9405X6X6	5
06U-206	5	08U-670	5	9405X8X8	5
06U-406	5	08U-758	5	9405X12X12	2
06U-446	5	08U-760	5	C5205X4X4	2
06U-506	5	08U-J08	5	C5205X6	4
06U-508	5	08U-P08	5	C5205X6X6	4
06U-606	10	08U-P10	5	C5205X8	4
06U-608	5	08U-R70	5	C5205X10	2
06U-610	5	12U-112	10	FH-135X	1
06U-666	5	12U-116	2	FS-1100	1
06U-668	5	12U-412	5	FS-100	1
06U-686	5	12U-512	5	FS-200	1
06U-755	5	12U-514	2	H32406	50'
06U-756	5	12U-516	2	H42504	50'
06U-B05	5	12U-610	5	H42506	50'
06U-B06	5	12U-612	10	H42508	50'
06U-B46	5	12U-614	5	H42512	50'
06U-B66	5	12U-616	2	H42516	50'
06U-J04	5	12U-672	2	T-401	1
06U-J06	5	12U-J12	5		

Assortments

CA-50 Coll-O-Crimp Super I Assortment

(with Cabinet)

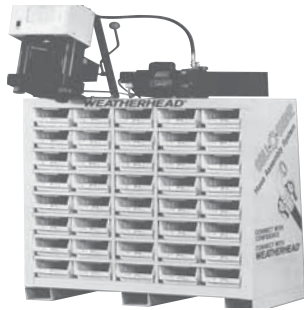

The CA-50 assortment includes everything you need to service your larger hydraulic applications. Five sizes of 2 wire hose and four sizes of 4 wire hose combined with a variety of hose ends and adapters gives you the coverage you need. Included with this assortment is a 40-drawer cabinet for mounting your press and storage. Also available are assortments with a cut-off saw or less the equipment.

CA-50

Includes contents listed below.

CA-50-CO

Includes contents listed below less equipment and cabinet.

CA-50-NH

Includes contents listed below less hose.

CA-50-60A

Includes contents listed below plus T-60A Saw.

CA-50 Contents

Catalog Number	Qty.	Catalog Number	Qty.	Catalog Number	Qty.	Catalog Number	Qty.
04U-102	5	08U-510	5	43012U-112	2	C5165X6	10
04U-104	10	08U-512	5	43012U-612	2	C5165X8	10
04U-106	5	08U-608	10	3012U-G12	1	C5165X12	5
04U-504	5	08U-610	5	43012U-G42	1	C5205X4	4
04U-506	5	08U-612	5	43012U-G72	1	C5205X4X4	2
04U-604	10	08U-668	5	43016U-116	2	C5205X6	4
04U-605	5	08U-670	5	43016U-616	2	C5205X6X6	4
04U-606	5	08U-688	5	43016U-G16	1	C5205X8	4
04U-664	5	08U-758	5	43016U-G46	1	C5205X8X8	4
04U-B04	5	08U-760	5	43016U-G76	1	C5205X10	2
04U-J04	5	08U-J08	5	43020U-120	1	C5205X12	2
06U-104	10	08U-P08	5	43020U-620	1	C5205X16	1
06U-106	10	08U-P10	5	43020U-G20	1	C5315X8	1
06U-108	5	12U-112	10	43020U-G50	1	C5405X6	2
06U-406	5	12U-116	2	43020U-G80	1	C5405X6X6	2
06U-506	5	12U-412	5	9205X2X2	5	C5405X8	2
06U-508	5	12U-512	5	9205X4X4	5	C5405X8X8	2
06U-604	5	12U-610	5	9205X6X6	5	C5405X10	1
06U-606	10	12U-612	10	9205X6X8	5	C5515X8	1
06U-608	5	12U-614	5	9205X8X6	5	H24504	50'
06U-610	5	12U-616	2	9205X8X8	5	H24506	50'
06U-666	5	12U-672	2	9205X12X12	2	H24508	50'
06U-668	5	12U-692	2	9205X16X16	1	H24512	50'
06U-755	5	12U-J12	5	9405X4X4	5	H24516	50'
06U-756	5	16U-116	5	9405X6X6	5	H43008	50'
06U-B06	5	16U-516	2	9405X8X8	5	H43012	50'
06U-B66	5	16U-616	5	9405X12X12	2	H43016	50'
06U-J06	5	16U-676	1	9405X16X16	1	H43020	50'
06U-J08	5	16U-J16	1	C-40X	1	T-420-N	1
06U-P08	5	43008U-108	2	C5105X4	2	FS-1100	1
08U-106	5	43008U-608	2	C5105X6	2	FS-100	1
08U-108	10	43008U-G08	1	C5105X8	2	FS-200	1
08U-112	5	43008U-G41	1	C5105X12	1	FS-3100	1
08U-508	5	43008U-G71	1	C5165X4	10		

Assortments

FT1341 Thread Measuring Kit

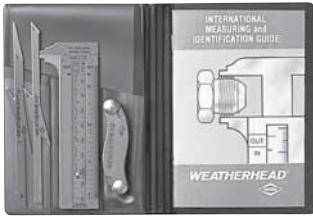

Measuring tube and pipe fitting threads can be a most difficult task if not completely understood. Tools needed include a thread pitch gauge, calipers and seat angle gauges. To aid you, Eaton has a kit to fit your needs; the FT1341 thread measuring kit.

This handy kit includes:

- Thread pitch gauge (Imperial and metric)
- Inside/outside caliper (inches and millimeters)
- 2 seat angle gauges (37°/45° and a 12°/30°)
- How to identify fluid ports and connectors bulletin
- Carrying case for easy convenient and storage

Weight: .5 lb.

TA-1004 Metric Thread Identification Kit



Contained in a durable steel carrying case, TA-1004 will help you with identification of metric, British pipe, and JIS thread configurations. Identification pieces are configured for 20 metric and 8 British pipe sizes.

This handy kit includes:

- Steel carrying case
- Stainless steel caliper
- Metric and british thread pitch gauges
- British thread measuring templates (4 measuring 8 sizes) made of durable aircraft grade aluminum
- Metric Thread Measuring Templates (10 measuring 20 sizes) made of durable aircraft grade aluminum
- Kit content identification chart

Assortments

SS-85 • Standard Brass Fittings Assortment



Instant service for service stations, car dealers, and repair shops. Contains 85 of the fastest moving Weatherhead brass fittings.

Compact, lightweight plastic box stores easily in a drawer, shelf or service truck. Saves you time and money by having the right fitting when it is needed. Eliminates searching and make-shift repairs by giving you the right part when you need it most.

Size

11" wide, 1-3/4" high, 6-3/4" deep.

Weight

3-1/4 lbs.

Part Number	Qty.
105x3	5
105x4	5
105x5	10
202x4	5
202x5	5
3151x2	2
3220x4x2	5
3300x2	5
402x4	2
60x3	5
60x4	10

Part Number	Qty.
60x5	5
60x	5
62x3	2
62x4	5
62x5	5
62x6	2
68x4	2
BF-40X	1

SS-86 • Compression Fittings Assortment



Assortment contains 80 of the fastest moving compression fittings.

Size

11" wide, 1-3/4" high, 6-3/4" deep.

Weight

3-1/2 lbs.

Part Number	Qty.
60x3	5
60x4	10
60x5	5
60x6	5
61x3	5
61x4	5
61x5	5
61x6	5
62x3	5

Part Number	Qty.
62x4	5
62x5	5
62x6	2
68x3	2
68x4	5
68x5	2
69x3	2
69x4	5
69x5	2
BF-40X	1

SS-87 • Inverted Flare Assortment



Assortment contains 84 of the fastest moving inverted fittings.

Size

11" wide, 1-3/4" high, 6-3/4" deep.

Weight

3-1/2 lbs.

Part Number	Qty.
105x3	5
105x4	5
105x5	5
105x6	5
202x3	5
202x4	5
202x5	5
202x6	2
302x3	5

Part Number	Qty.
302x4	5
302x5	5
302x6	2
402x3	5
402x4	5
402x5	5
402x6	5
7896x3	5
7896x4	5
BF-40X	1

Assortments

SS-88 • Brass Pipe Assortment



Assortment contains 59 of the fastest moving brass pipe fittings.

Size
11" wide, 1-3/4" high, 6-3/4" deep.

Weight
3-1/2 lbs.

Part Number	Qty.
3152x2	5
3152x4	5
3152x6	2
3220x4x2	2
3220x6x4	2
3300x2	5
3300x4	2
3326x2	5
3326x4	5

Part Number	Qty.
3326x6	2
3350x2	5
3350x4	4
3350x6	2
3400x2	5
3400x4	2
3400x6	2
3500x2	2
3500x4	2
BF-40X	1

BF-40 • Hydraulic Brake Fittings Assortment



The BF-40 assortment of fast moving hydraulic brake fittings is a must for any shop doing brake service work. Contains the adapters needed to convert large size ports in master cylinders to accept standard steel brake lines plus the brass tees used in the installation of electric towed trailer brakes.

Assortment is organized in a compact, handy plastic box for easy selection.

Size
1" wide, 1-3/4" high, 6-3/4" deep.

Weight
4 lbs. (approx.)

Part Number	Qty.
7818	2
7828	2
7829	2
7897	2
7898	2
7900	2
7901	2
7904	2
7905	2

Part Number	Qty.
7906	2
7908	2
7910	2
7911	2
7912	2
7913	2
7914	2
7917	2
7933	2
BF-40X	1

BF-41 • Hydraulic Brake Line Adapter Assortment



The BF-41 assortment contains the adapters needed to convert the oversize master cylinder ports to accept the inverted flare nut used on standard replacement steel brake lines. The adapters eliminate the need to cut line, install oversize nut and double flare tubing as well as converting the port to standard size threads for the life of the car. Extra standard nuts and the unions needed to connect two steel brake lines when a non-standard length is required are also included in the assortment. The contents including the illustrations of parts are shown on the inside cover of the box.

Size
11" wide, 1-3/4" high, 6-3/4" deep.

Weight
4 lbs. (approx.)

Part Number	Qty.
105x3	10
105x4	10
105x5	10
105x6	5
105x6x7	2
302x3	5
302x4	5
302x5	5
302x6	2
7818	2
7828	2
7829	2
7896x3	5
7896x4	5
7897	2
7908	2
7917	2
BF-40X	1

Assortments

BF-42 • RV Brake Line Adapter Assortment



The BF-42 assortment contains the adapter tees required to install the control switch used to coordinate the electric trailer brakes with the hydraulic brakes on towing vehicle. The assortment also contains inverted brake line nuts and unions needed to make up non-standard steel brake line lengths.

Size

11" wide, 1-3/4" high, 6-3/4" deep.

Weight

4 lbs.

Part Number	Qty.
105x3	10
105x4	10
105x5	10
105x6	5
105x6x7	2
302x3	5
302x4	5
302x5	5
7898	1

Part Number	Qty.
7900	1
7901	1
7904	1
7905	1
7906	1
7914	1
7921	1
7933	1
BF-40X	1

BF-43 • Metric Adapter and Tee Assortment



The BF-43 assortment contains metric thread connectors to adapt the three port sizes in late model GM cars to use a steel brake line with metric threads (M10x1.0) and standard flare (Weatherhead J series). Included as well are metric adapters to convert European Bubble flare type ports to accept standard 3/16" U.S. steel brake lines, and metric towed trailer brake tees used in controls of electric trailer brakes. The 3/16" unions are used for joining metric and U.S. steel brake lines to make up non-standard lengths.

Size

11" wide, 1-3/4" high, 6-3/4" deep.

Weight

4 lbs. (approx.)

Part Number	Qty.
105x3	10
105x4	5
1442	5
1443	5
302x3	5
7921	1
7934A	5
7935	1
7936	1

Part Number	Qty.
7937	1
7940	5
7941	5
7896x3	5
7896x4	5
BF-40X	1

Assortments

DC-121 • Plastic Drain Cock Assortment



This kit can address all your plastic drain cock needs with a full assortment of Weatherhead domestic and offshore drain cocks. This kit comes complete with a plastic box and a label with part number and application information.

Part Number	Qty.
110	2
111	2
112	2
113	2
114	2
115	2
116	2
117	2
135	2
145	2

PC-48 • Push Connect Fittings Assortment



Weatherhead PUSH > CONNECT fittings are designed for quick assembly without the need for a wrench. Ideal for pneumatic applications where space is tight. Then fittings are also easily disconnected; simply depress the collet ring with two fingers and withdraw the tube. The PC-48 provides the 48 most popular PUSH > CONNECT fittings in a compact, handy plastic box to make your assortment organized and accessible.

Part Number	Qty.	Part Number	Qty.
1162x2	5	1168x6	5
1162x4	5	1168x6x6	5
1162x6	5	1168x6x8	2
1164x2.5	5	1168x8	5
1164x4	5	1168x8x8	2
1164x6	5	1169x2.5S	5
1164x8	2	1169x2S	5
1165x2.5	5	1169x2x4S	5
1165x4	5	1169x4S	5
1165x6	5	1169x4x4S	5
1165x8	2	1169x4x6S	5
1166x4	5	1169x6S	5
1166x4x4	5	1169x6x6S	5
1166x6	5	1169x8S	2
1166x6x6	2	1169x8x4S	2
1168x2	2	1171x4S	5
1168x2.5	5	1171x4x4S	5
1168x2.5A	5	1171x6S	5
1168x2.5x4	5	1172x4S	5
1168x2x4	5	1172x4x4S	5
1168x4	5	1174x2	5
1168x4A	5	1174x4	5
1168x4x4	5	CL-499	1
1168x4x6	5	FC-16X	1
1168x5	5		
1168x5x4	5		

BA-84 • Steel Brake Line Assortment

The BA-84 attractive lobby merchandiser displays domestic as well as import car (British, European, and Japanese) steel brake lines. The BA-84 puts brake lines where users can make fast and easy selection from a complete inventory protected by sturdy cardboard color-coded tubes.

The corrosion- and vibration-resistant double wall steel brake lines are easily formed into the configurations you need without kinking. Longer or non-standard lengths can be made up by joining two lines with a Weatherhead union of the proper thread size.

The BA-84 includes all sizes of the 3/16", 1/4" and 5/16" Weatherhead steel brake lines for domestic cars and trucks plus a sturdy steel rack. Order the SB

series (Jaguar, M.G., Triumph), SC series (BMW, Mercedes, Peugeot, Porsche, Volkswagen), SJ series (Mazda, Nissan, Toyota) and Weatherhead import car steel brake lines and unions from listings in brake line section of this catalog. See page 431.

Increase your sales—
Organize your inventory—
Make selections easy—
Discover the results of putting this proven money maker to work for you—
Install a BA-84.

Part Length	Number	Qty.
3/16" LINES		
6"	S306	4
8"	S308	4
12"	S312	4
20"	S320	4
30"	S330	4
40"	S340	4
51"	S351	4
60"	S360	4
72"	S372	4
1/4" LINES		
12"	S412	4
20"	S420	4
30"	S430	4
40"	S440	4
51"	S451	4
60"	S460	4
5/16" LINES		
12"	S512	4
20"	S520	4
30"	S530	4
40"	S540	4
51"	S551	4
60"	S560	4
Rack	BA-84X	1

Assembly Equipment





BA-24 • Steel Brake Line Assortment

The BA-24 assortment includes an assortment of 5/16" steel brake lines and a rack for wall or bin installation. The multi-walled corrosion-resistant tubing can be easily formed for time saving installation.

All lines have color-coded label attached for easy identification. Non-standard lengths can be made up by joining two standard lengths with a 302x5 union.

Weight
6 lbs

Length	Part Number	Qty.
12"	S512	4
20"	S520	4
30"	S530	4
40"	S540	4
51"	S551	4
60"	S560	4
Rack	BA-24X	1

BA-28 • Steel Brake Line Assortment

BA-28 contains 3/16" easy to form, anti-corrosive, multi-walled steel brake lines for Japanese vehicles. The SJ lines with 10-1.0mm threads (standard flare) can be joined

to form longer lines by using the 7934A Japanese metric union. The handy wall rack is included.

Weight
6 lbs

Length	Part Number	Qty.
8"	SJ308	4
12"	SJ312	4
20"	SJ320	4
30"	SJ330	4
40"	SJ340	4
51"	SJ351	4
60"	SJ360	4
Rack	BA-28X	1

BA-38 • Steel Brake Line Assortment

BA-38 contains six different lengths made of 3/8" anti-corrosive non-standard multi-walled, easily formed, steel tubing with inverted flare nuts attached. All lines have color-coded label for

easy identification. Non-standard length lines may be fabricated by joining two 3/8" steel lines with a 302x6 union.

Weight
8 lbs.

Length	Part Number	Qty.
12"	S612	4
20"	S620	4
30"	S630	4
40"	S640	4
51"	S651	4
60"	S660	4
Rack	BA-38X	1

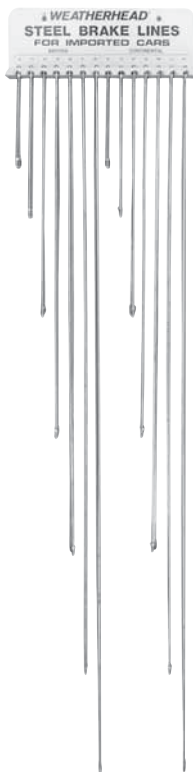

BA-48 • Steel Brake Line Assortment

BA-48 contains the most popular steel brake lines and an easy to install rack. The 3/16" and 1/4" steel brake lines are available in six different lengths. Each steel brake line has a standard inverted flare nut on one end and a long thread inverted flare nut on the other end for better sealing. Easy to

form, multi-walled steel tubing resists corrosion and vibration.

Non-standard length lines may be fabricated by joining two 3/16" lines with a 302x3 and two 1/4" lines with a 302x4.

Weight
10-1/2 lbs.

Length	Part Number	Qty.
3/16" LINES		
12"	S312	4
20"	S320	4
30"	S330	4
40"	S340	4
51"	S351	4
60"	S360	4
1/4" LINES		
12"	S412	4
20"	S420	4
30"	S430	4
40"	S440	4
51"	S451	4
60"	S460	4
Rack	BA-48X	1

BA-56 • Steel Brake Line Assortment

BA-56 contains 3/16" easy to form, anti-corrosive, multi-walled steel brake lines for British and European cars. The SB lines with 3/8-24 threads (Bubble Flare) can be joined to form longer lines by using the 7940 metric union. SC lines with 10X1.0mm threads (Bubble Flare) can be joined with the 7941 metric union. The handy wall rack is included.

Weight
10 lbs.

Length	Part Number	Qty.
British 3/8-24 Thread		
8"	SB308	4
12"	SB312	4
20"	SB320	4
30"	SB330	4
40"	SB340	4
51"	SB351	4
60"	SB360	4

Length	Part Number	Qty.
European 10-1.0mm Thread		
8"	SC308	4
12"	SC312	4
20"	SC320	4
30"	SC330	4
40"	SC340	4
51"	SC351	4
60"	SC360	4
Rack	BA-56X	1

Assortments

AB-1400 • Air Brake Fittings Assortment



The AB-1400 contains DOT approved brass air brake fittings for servicing nylon brake and secondary air lines. Selecting the proper fittings from the 63-drawer cabinet included with the assortment is easy. Clear, wide plastic drawers with color-coded labels make identification of shapes and sizes quick and simple. Order Weatherhead NT100 nylon air brake tubing to complete your nylon air brake line service center.

Part Number	Qty.
1460x4	10
1460x6	20
1460x8	10
1460x10	10
1460x12	10
1461x4	5
1461x6	10
1461x8	5
1461x10	5
1461x12	5
1462x4	5
1462x6	10
1462x8	5
1462x10	4
1462x12	2
1464x6	5
1464x8	5
1466x6	5
1466x6x6	5
1466x8	5
1468x4	5
1468x4x4	5
1468x6	10
1468x6x2	5
1468x8	5
1468x10	5
1468x12	4
1469x4	5

Part Number	Qty.
1469x4x4	5
1469x6	10
1469x6L	5
1469x6x2	5
1469x6x6	5
1469x8	5
1469x8x4	5
1469x10	5
1469x10x6	4
1469x12	4
1471x4	5
1471x6	5
1472x6	5
1472x8	5
1480x6	5
1480x6x6	5
1480x8	5
1480x10	4
1484x4	20
1484x6	20
1484x8	20
1484x10	10
1484x12	10
C-63X	1
CL-497	1

AB-140 • 1400 Series Air Brake Fittings Assortment



This assortment of 1/4", 3/8", and 1/2" air brake fittings designed for use with NT100 nylon air brake tubing provides the coverage needed for service work by fleets, repair shops, and farm implement dealers. The DOT-approved air brake fittings are easily selected from the cabinet with 16 plastic drawers and color-coded labels included in the assortment.

Part Number	Qty.
1460x4	20
1460x6	20
1460x8	20
1461x4	10
1461x6	10
1461x8	5
1462x4	5
1462x6	10
1462x8	4
1468x4	10
1468x6	10
1468x8	5
1469x4	5
1469x6	5

Part Number	Qty.
1469x8	5
1484x4	20
1484x6	20
1484x8	20
145	10
CL-16-3	1
FC-16X	1
W15310	5

Assortments

QC-18



Designed as a glove box sized emergency repair kit, the QC-18 assortment contains Q-CAB® tube unions in 5/32", 1/4", 3/8", and 1/2" sizes, also included is a T-191 tubing cutter. The contents are contained in a convenient carrying case measuring 1-1/4" x 3-3/4" x 7".

Component Part No.	Qty.
1862x2.5	2
1862x4	2
1862x6	2
1862x8	2
T-191	1
QC-18X	1

QC-180



The QC180 contains tube unions, male connectors, swivel male 45° elbow, male 90° elbows, and repair kits in popular 1/4", 3/8", and 1/2" tube sizes designed for DOT Truck and Trailer Air Brake System needs (see complete listing at right in table). The Q-CAB® fittings are field proven with over millions of miles of leak free performance. Their design can save up to 75 percent of the assembly time over conventional compression fittings. These fittings are contained in a case measuring 1-3/4" x 6-3/4" x 1-3/4".

Component Part No.	Qty.
1869x6x6	2
1862x4	2
1869x8x8	1
1862x6	2
1880x4x4	2
1862x8	2
1880x6x6	2
1868x2.5	2
1880x8x8	1
1868x3	2
1800Kx4	2
1868x4x4	2
1800Kx6	2

Component Part No.	Qty.
1868x6x6	2
1800Kx8	2
1868x8x8	2
1800TRK	1
1869x4x4	2
BF-40X	1

QC-1800



This assortment contains a solid inventory of popular Weatherhead Q-CAB® fittings designed for DOT Truck and Trailer Air Brake System needs (see complete listing at right in table). The Q-CAB® fittings are field proven with over millions of of leak free performance. Their design can save up to 75 percent of the assembly time over conventional compression fittings.

Component Part No.	Qty.
1800Kx2.5	4
1862x10	2
1868x12	2
1874x6x6	1
1800Kx3	4
1868x2.5x1	5
1869x4	5
1874x8x8	1
1800Kx4	4
1868x2.5	5
1869x4x4	5
1880x4x4	5
1800Kx6	4
1868x3	5
1869x6	5
1880x6x6	5
1800Kx8	4
1868x4	5
1869x8	5
1880x8x8	5
1800Kx10	2
1868x4x4	5
1869x8x8	5
1880x10	2

Component Part No.	Qty.
1800Kx12	2
1868x6	5
1869x10	2
1880x12	2
1862x2.5	2
1868x6x6	5
1869x4S	5
1800T	1
1862x3	5
1868x8	5
1869x4x4S	5
CL-503	1
1862x4	5
1868x8x8	5
1869x6S	5
FC-16X	1
1862x6	5
1868x10x6	2
1869x8S	5
T-191	1
1862x8	5
1868x10	2
1874x4x4	1

Assortments

AB-45 • Air Brake Fittings Assortment



This assortment of draincocks, shutoffs, and air brake fittings for use with 1/4", 3/8", and 1/2" copper tubing is a must for jobbers and fleet service shops. Provides excellent coverage for air brake tube and hose service requirements. The large plastic drawers and the illustrated labels for the 15 drawer cabinet included in the assortment make positive part selection simple and quick.

Part Number	Qty.
1360x6	20
1360x8	20
1360x10	10
1360x12	10
1361x6	20
1361x8	5
1361x10	5
1362x4	5
1362x6	10
1362x8	5
1362x10	5
1368x6	10
1368x6x2	5
1368x6x6	5
1368x8	5
1368x10	5
1369x4x4	5
1369x6	10
1369x8	5
1380x6	5
1390x6	5
1391x6	5
145	10

Part Number	Qty.
33806-A	20
33806-B	5
33806B-Y06	2
33806B-Y24	5
33806B-Y28	5
33806B-Y34	5
33806B-Y38	5
6707	1
6708	1
6709	1
6747	1
6748	1
6749	1
FH-15X	1
FS-800	1
W05465	5
W14630	10
W15310	5
W76150	5
W79850	3
W79851	3

Assortments

SA-1 • Secondary Air Systems Kit



Ideal for fleet repair shops, truck dealers, garages and truck stops. SA-1 contains an assortment of popular 1/8" and 1/4" brass fittings plus 200' of Weatherhead NT100 SAE J844 Nylon tubing. The 1/8" fittings are Weatherhead SELFALIGN® and 1/4" fittings are Weatherhead 1400 series air brake. The sturdy box keeps the tubing and fittings together for quick and easy servicing of the tubing used on shifters, PTO's, wipers, horns, remote air, instrumentation, etc. All of the parts are organized at your finger tips. The SA-1 is a must for all vehicle air system maintenance facilities.

Size

15" wide, 3-1/2" high, 14-1/2" deep.

Part Number	Qty.
1460x4	10
1461x4	5
1462x4	2
1464x4	1
1468x4	2
1468x4x1	2
1468x4x4	2
1469x4	2
1469x4x4	2
1484x4	5
601x2	10

Part Number	Qty.
611x2	5
621x2	2
661x2	2
681x2	2
681x2x1	2
691x2	2
691x2x1	2
BF-40X	1
NT10002BK-100	100'
NT10004BK-100	100'

SA-2 • Secondary Air Systems Kit



The SA-2 assortment enables you to supply fleets and dealers with fittings and tubing for 1/4" and 3/8" O.D. air brake applications. 1/8" O.D. tubing and fittings are also supplied for applications such as transmission shifter, air horn, gauge and flat adjustment. A cabinet is also supplied for easy storage on shelves and bench tops.

Part Number	Qty.
1460x4	10
1460x6	20
1461x4	5
1461x6	10
1462x4	5
1462x6	10
1464x4	2
1464x6	2
1466x6	5
1468x4	5
1468x4x4	5
1468x4x6	2
1472x4	5
1472x6	5
1472x6x6x6	5
1484x4	10
1484x6	10
1485x4	10
1485x6	10
1468x6	10

Part Number	Qty.
1468x6x2	5
1468x6x6	5
1468x6x8	5
1469x4	5
1469x4x4	5
1469x6	10
1469x6x6	5
601x2	10
611x2	10
621x2	5
661x2	5
681x2	5
681x2x1	2
691x2	5
691x2x1	2
BL-456-X	1
FS-SA-2	1
NT10002BK-100	100'
NT10004BK-100	100'
NT10006BK-100	100'

Equipment - Cabinets

Cabinets

C-40X Stock Cabinet



Ideal for mounting the T-400-1 Coll-O-Crimp I Press and Pump or T-420-1 Coll-O-Crimp Super I. The sturdy C-40X Cabinet contains 40 heavy-duty plastic drawers that can be divided into one, two, three, or four compartments providing space for a large selection of Coll-O-Crimp hose ends and adapters.

Drawers

PD-40 (one drawer)

Dividers

PD-20 (individual)

Size

46-1/2" high, 40" wide, 26" deep at base, 18" deep at top

Weight

228 lbs.

FH-135X Stock Cabinet



The sturdy FH-135X Cabinet contains 50 heavy-duty plastic drawers that can be divided into one, two, or three compartments allowing you ample space for a large selection of Coll-O-Crimp hose ends and adapters. Ideal for mounting the Coll-O-Crimp I Press and Pump.

Drawers

PD-95 (one drawer)

Dividers

PD-15 (individual)

Size

46-1/2" high, 33" wide, 14-1/2" deep

Weight

115 lbs.

FH-15X Stock Cabinet



Here is the ideal way to organize your inventory of hose ends and adapters. The rugged FH-15X Cabinet contains 15 plastic drawers for stocking hose ends and adapters.

Drawers

PD-95 (one drawer)

Dividers (individual)

PD-15

Size

13-5/8" high, 14-3/8" deep, 30-1/4" wide

Weight

45 lbs.

FH-40X Stock Cabinet

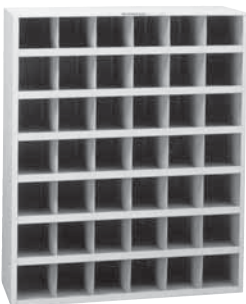

Provides convenient storage areas for those large size fittings and hose ends. This durable 20 gauge steel cabinet is made to handle abuse.

Size

35" wide, 42" high, 12" deep

Weight

200 lbs.

Note: Will not support Weatherhead Coll-O-Crimp equipment.

Equipment - Cabinets

Cabinets

FH-72X Stock Cabinet

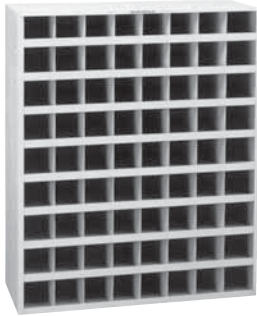

Large capacity all-welded cabinet provides 72 storage compartments. Fabricated from 20 gauge steel, the FH-72X will provide years of continued service.

Size
35" wide, 42" high, 12" deep

Weight
200 lbs.

Note: Will not support Weatherhead Coll-O-Crimp equipment.

C-5X Stock Cabinet



This mini-cabinet is designed to contain your oversized Weatherhead hose ends which may not currently have an organized home.

Size
30" wide, 5-7/8" high, 9-5/16" deep

Weight
10 lbs.

TC-20 Collet Cabinet



The TC-20 Cabinet provides you easy access to all of your tooling needs. There is ample space for collets, spacer rings, and related Coll-O-Crimp tooling.

Size
28-1/2" high, 26-1/2" wide, 12-3/4" deep

Weight
37-1/2 lbs.

HD-1X Hose Cabinet



The HD-1X Cabinet offers you the ideal solution for keeping 50 foot lengths of hose off your floor. Vertical slots in the cabinet keep your hoses organized and clean. Consider bolting an FH-15X Stacking Cabinet on top of the HD-1X to keep an inventory of hose ends readily available.

Size
36" high, 24" deep, 31" wide

Weight
83 lbs.

Equipment - Cabinets & Bags

Cabinets and Bags

HD-2X Hose Center Display

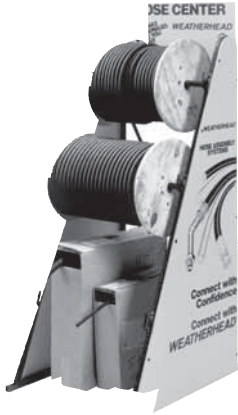

The HD-2X hose display is built with a heavy steel inner frame which supports the weight of the hose reels, while its tough wooden sides provide additional durability. It is designed to hold both Weatherhead bulk reels and boxed product. Handles are even provided to make loading the hose as safe and easy as possible.

Measurements
22" wide x 30" deep x 57" tall

Weight
54 lbs. (UPS Shipping)

Maximum Capabilities
(3) Reels or (2) Reels & (4) Boxes
(Hose not included)

T-460-10BB Coll-O-Crimp Tool Box



The T-460-10BB Tool Box complements our T-460 and T-462 portable crimpers by offering you storage for your collets, spacer rings, and perhaps an assortment of hose ends.

Measurements
25"x9"x8"

T-460-TR Tool Rack



The T-460-TR wall-mounted tool rack is rugged and built to last! The perfect shop accessory for Coll-O-Crimp machines, the T-460-TR stores up to 10 collets and 4 spacer rings—organized and within easy reach.

(The T-460-TR rack does not include tooling)

Measurements
24 -1/2" Wide x 16" High x 7-1/2" Deep

Weight
16 lbs.

Plastic Bags



Weatherhead heavy duty plastic bags for Weatherhead fittings come in sizes 5"x6", 6"x10", and 8"x12". The bags include convenient spaces for labeling.

Catalog Number	Description	Qty
5x6 PB	Plastic Bag	100
6x10 PB	Plastic Bag	100
8x12 PB	Plastic Bag	100

Equipment - Labels

Label Sets

Self Adhesive Label Sets



For C-40X, FH-15X, and FH-135X Cabinets

Label Number	Description
FS-100	Swivel Adapters
FS-200	JIC Steel Adapters
FS-300	Split Flange Adapters
FS-400	Field Attachable Hose Ends – 009 'B' Series
FS-500	Barb-Tite® 100 'B' and 105 'B' Series Hose Ends
FS-600	Field Attachable Hose Ends – 069 'D' & 247 'N' Series
FS-700	Field Attachable Hose Ends – 425 'N' Series
FS-800	Field Attachable Hose Ends – 338 'B' Series & Brass Air Brake Fittings for Copper Tubing
FS-1100	Coll-O-Crimp Hose Ends – 'U' Series
FS-1200	Coll-O-Crimp Hose Ends – 'E' Series
FS-1500	Coll-O-Crimp Hose Ends – 069 'E' Series
FS-1600	7000 Series Flareless Fitting
FS-1800	Coll-O-Crimp Hose Ends – 470 'E' Series and 570 'S' Series
FS-2000	Steel Pipe
FS-2200	Ready-Lok Hose Ends and Adapters
FS-2300	Drain Cocks, Valves and Select 338 'B' Series Hose Ends
FS-2400	FOR-SEAL Adapters Label Set
FS-2500	Metric Hose Ends ('U' Series) and Metric Flareless Nuts/Sleeves
FS-2800	Field Attachable Hose Ends – 213 'N' Series
FS-2900	Coll-O-Crimp Hose Ends – 338 'P' Series
FS-3100	Coll-O-Crimp Hose Ends – 430 'U' Series No-Skive
FS-3200	Coll-O-Crimp Hose Ends – 757 'E' Series
FS-3300	Quick Connect Air Brake 1800 Series
FS-3500	Coll-O-Crimp Hose Ends – 336 'E' Series
FF90645	WeatherGRIP Hose Ends - 'Z' Series
FF90646	E-Z Clip Label Set
FF90686	4SP/6SP Hose Ends Label Set

A2103 Mylar Hose Labels



Eaton now offers Mylar labels for marking hose assemblies. They are self-adhesive Mylar strips, 1" wide by 3-3/4" long, with a 1" x 1" white area on one end for printed information. They are supplied on a roll of 2000 labels with each perforated page containing eight labels. The format is suitable for use in typewriters and tractor-feed or friction-drive printers.

Whether for compliance with federal hose assembly labeling requirements, or for simply meeting customer demands for labeling hose assemblies, we strongly recommend labeling become part of your hose assembly "manufacturing" procedure. The National Highway Traffic Safety Administration places responsibility for labeling an air brake hose assembly in the hands of the "manufacturer" of the hose assembly. (Not the manufacturer of the hose or hose ends.) For a summary

of air brake hose assembly labeling recommendations, see "Air Brake Hose Assembly Guidelines." For specific air brake hose assembly regulations, consult "Federal Motor Vehicle Safety Standard (FMVSS) 571.106," available from NHTSA, at the address listed below. For use other than air brake applications, customers may want additional information on the labels. Generally, the labels will accept 9-10 characters per row, on 4 or 5 rows. The information can be handwritten, typed, or printed on the labels. The main concern is resistance to the elements. Procedure for applying the labels is simple:

1. Print the appropriate information on the label.
2. Wrap the tag around the hose assembly; printed end first.
3. Cover the printed end with the clear mylar tail of the label.
4. The clear tail will protect the printed area from the elements.

Office Of Vehicle
Safety Standards
National Highway Traffic
Safety Administration
400 Seventh Street SW
Washington, DC 20590
Phone (202) 366-5317
www.nhtsa.dot.gov

Equipment - Field Attachable

Field Attachable Assembly Equipment

 Refer to safety information regarding Coll-O-Crimp hose, hose fittings and assembly equipment compatibility on pages A-2-3.

T-300 Field Attachable Hose End Assembly Machine



The Weatherhead T-300 machine eliminates lost time and hard work when making replacement hose assemblies with bulk hose and field attachable hose ends. Simple, effortless operation provides uniform, safe assemblies time after time. This heavy-duty machine assembles straight, swivel, elbow and flange-type ends on all medium and high pressure wire braid hose from 3/16" through 2" I.D.

Part Number	Description
T-300	Assembly Machine – complete with tripod stand, adjustable locator, chuck handle and foot switch
T-300X	Assembly Machine without tripod stand
T-301	Tripod Stand

Motor

Universal, reversible, 110-115 volts, 25-60 cycle, 1/2 H.P., 8 amps

Weight

167 lbs.

Mandrel Assembly Tools



These tools are required for assembling 069 'D' Series hose ends in sizes 4 through 12 to prevent cutting the hose inner tube. Size 16 through 32 mandrels are used as a holding device when assembling 069 'D' Series swivel ends. Mandrels can be ordered individually.

Hose I.D.	Part Number	Swivel End Application
3/16"	T-JS4	SAE 37° & 45°
1/4"	T-JS5	SAE 37° & 45°
5/16"	T-J6	SAE 37°
5/16"	T-S6	SAE 45°
13/32"	T-JS8	SAE 37° & 45°
1/2"	T-JS10	SAE 37° & 45°
5/8"	T-J12	SAE 37°
5/8"	T-S12	SAE 45°



Hose I.D.	Part Number	Swivel End Application
7/8"	T-J16	SAE 37°
1-3/8"	T-J24	SAE 37°
1-13/16"	T-J32	SAE 37°

Equipment - Field Attachable

Field Attachable Assembly Equipment

 Refer to safety information regarding Coll-O-Crimp hose, hose fittings and assembly equipment compatibility on pages A-2-3.

T-101A Barb-Tite End Assembly Tool



Assembly of Barb-Tite push-on hose ends is made easy with this handy tool. Easy and fast operation assures dependable, leak proof assemblies. Simply clamp hose in jaws, place hose end on push rod and pull the handle. Engineered for a lifetime of rugged service.

Weight

1 lb.

Capacity

1/4" to 1/2" I.D. hose only.

T-201 Barb-Tite End Assembly Tool



This bench-mounted tool is actually two tools in one. Not only does it assemble Barb-Tite hose ends, it is also a hose cutter. To cut your hose, simply retract the handle, place the hose in the cutter area and pull the handle. After cutting the hose to the desired length, place the hose under the cam handle locking it in place with the hose end aligned with the appropriate mark on the label. Place the barbed end of the fitting against the end of the hose and then pull the handle forward to complete the installation. The T-201 assembly tool is an easy-to-use tool that does everything you need to create a hose assembly.

Replacement Blade T-201B

Note

This tool is designed to cut fiber-reinforced rubber hose only.

Capacity

1/4" to 3/4" I.D. hose

